

**HiFi ENGINE®**

For more Hi-Fi manuals and set-up information  
please visit [www.hifiengine.com](http://www.hifiengine.com)

# SERVICE MANUAL

## 4-CHANNEL RECEIVER **QX-646** KUW,FW

**NOTE:**

MODEL QX-646 COMES IN TWO VERSIONS DISTINGUISHED AS FOLLOWS:

Round label on rear panel	Voltage	Type
KUW FW	120V only 5-position selector	UL approved (U.S.A) General export model with de-emphasis selector switch

# CONTENTS

1.	SPECIFICATIONS .....	3
2.	CONNECTION DIAGRAM .....	5
3.	FRONT PANEL FACILITIES .....	7
4.	BLOCK DIAGRAM .....	9
5.	PARTS AND P.C. BOARD LOCATION	
5.1	Top View .....	11
5.2	Bottom View .....	12
6.	DISASSEMBLY .....	13
7.	SIGNAL PATH AND CIRCUIT FUNCTIONS	
7.1	Recording and Playback of CD-4 Discs .....	14
7.2	1/2 Equalizer .....	15
7.3	2/2 Equalizer .....	16
7.4	Low Pass Filter .....	16
7.5	AF Amplifier Assembly .....	16
7.6	High Pass Filter .....	16
7.7	Phase Locked Loop FM Detector .....	16
7.8	Automatic Selectivity Control .....	17
7.9	Sub Equalizer .....	17
7.10	Low Pass Filter .....	17
7.11	Automatic Noise Reduction System .....	17
7.12	Phase Splitter .....	18
7.13	Separation Control Circuit .....	18
7.14	Matrix Circuit .....	18
7.15	Muting Circuit .....	18
8.	ALIGNMENT PROCEDURE	
8.1	FM/AM IF Alignment .....	19
8.2	FM/AM Tracking Alignment .....	20
8.3	MPX Decoder Alignment .....	20
8.4	Other Alignments .....	21
8.5	Adjustment of Phase Locked Loop Oscillation Frequency .....	22
8.6	Carrier Level Adjustment .....	22
9.	DIAL CORD STRINGING .....	23
10.	LEVEL DIAGRAM .....	24
11.	EXPLODED VIEW AND PARTS LIST .....	25
12.	SCHEMATIC DIAGRAMS, P.C. BOARD PATTERNS AND PARTS LISTS	
12.1	Circuit Connection Diagram and Miscellaneous Parts .....	29
12.2	Tuner Assembly (AWE-003) .....	33
12.3	Equalizer and Matrix Circuit Assembly (AWM-045) .....	40
12.4	Sub Channel Circuit Assembly (AWX-051) .....	46
12.5	Decoder Circuit Assembly (AWM-031) .....	56
12.6	Control Amplifier Assembly (AWG-015) .....	61

12.7	Muting Circuit Assembly (AWM-046)	65
12.8	Power Amplifier Assembly (AWH-019)	66
12.9	AF Amplifier Assembly (AWK-025)	70
12.10	Power Supply Circuit Assembly (AWR-035)	72
12.11	Balance Volume Assembly (AWX-028)	74
12.12	Switch Circuit Assembly (AWS-023)	76
12.13	Speaker Switch Circuit Assembly (AWS-024)	78
13.	PACKING METHOD AND PART NUMBERS	79



# 1. SPECIFICATIONS

## SEMICONDUCTORS

FETs	9
ICs	5
Transistors	109
Diodes	45

## AMPLIFIER SECTION

Continuous Power Output	
20Hz~20kHz (2 channels driven)	10W + 10W/10W + 10W(8Ω)
1kHz (4 channels driven)	10W x 4(8Ω), 11W x 4(4Ω)
1kHz (2 channels driven)	13W + 13W/13W + 13W(8Ω)
1kHz (Each channel driven)	15W + 15W/15W + 15W(4Ω)
15W/15W/15W/15W (8Ω)	
20W/20W/20W/20W(4Ω)	
Music Power Output (IHF)	80W(8Ω), 108W(4Ω)
Harmonic Distortion (Continuous Power Output)	Less than 1%
Intermodulation Distortion (Continuous Power Output)	Less than 1%
Power Bandwidth	
(IHF, 4 channels driven 8Ω)	15Hz~20kHz (H.D. 1%)
(IHF, 2 channels driven 8Ω)	10Hz~30kHz (H.D. 1%)
Output, Speaker	1 Pair for Front (4~16Ω)
Headphone	2 Pairs for Rear (4~16Ω)
Front (CH. 1, CH. 3)	
Damping Factor (1kHz, 8Ω)	40
Input Sensitivity/Impedance	
PHONO	2.5mV/100kΩ
AUX	180mV/90kΩ
TAPE MONITOR	180mV/90kΩ
TAPE MONITOR (DIN Connector)	180mV/90kΩ
Output Level	
TAPE REC	180mV
TAPE REC (DIN Connector)	30mV

Frequency Response	
PHONO (RIAA equalization)	30Hz~15kHz ±0.5dB
AUX, TAPE MON	10Hz~100kHz ±3dB
Tone Control	
BASS	+13dB, -12.5dB (100Hz)
TREBLE	+11.5dB, -8.5dB (10kHz)
Loudness Contour (Volume control set at -40dB position)	+10dB (100Hz), +5dB (10kHz)
Hum & Noise (IHF, Short-circuited, A Network)	
PHONO	More than 70dB
AUX, TAPE MON	More than 90dB

## CD-4 DEMODULATOR SECTION

Input Sensitivity	2.5mV (1~5mV Adjustable)
Input Impedance	100kΩ
Distortion	0.07%
S/N (IHF, A Network)	More than 70dB
Separation (STD Test Signal at 1kHz)	
Left - Right	50dB
Front - Rear	30dB
Frequency Response	20Hz~15kHz

## FM TUNER SECTION

Usable Sensitivity (IHF)	2.2μV
Capture Ratio (IHF)	3dB
Selectivity (IHF)	40dB
Signal-to-Noise Ratio	65dB
Image Rejection	More than 50dB
IF Rejection	More than 85dB
Spurious Rejection	More than 80dB
AM Suppression	50dB
Harmonic Distortion	
Mono	Less than 0.6%
Stereo	Less than 0.8%
Stereo Separation	
1kHz	More than 40dB
Sub Carrier Suppression	35dB
Antenna Input	300Ω Balanced
75Ω Unbalanced	
Muting	ON-OFF

## AM TUNER SECTION

Usable Sensitivity	
(IHF, Ferrite antenna)	300μV/m
(IHF)	15μV
Selectivity (IHF)	25dB
Signal-to-Noise Ratio	50dB
Image Rejection	More than 45dB
IF Rejection	More than 30dB
Antenna	Built-in Ferrite Loopstick Antenna

## MISCELLANEOUS

Built-in CD-4 Demodulator	
Regular Matrix Decoder	
SQ Matrix Decoder	
Power Requirements	AC 120V 60Hz or 110V, 120V, 130V, 220V and 240V (Switchable)
	50/60Hz
Power Consumption (Max.)	160W
AC Outlets	Switched 1, Unswitched 1
Dimensions	525(W) x 149(H) x 360(D) mm
	20-11/16(W) x 5-7/8(H) x 14-3/16(D) in.
Weight Without Package	12.3kg (27lb 2oz)
With Package	14.7kg (32lb 7oz)

## FURNISHED PARTS

FM T-type Antenna	1
CD-4 Test Record (PQX-1011)	1
Polishing Cloth	1
Operating Instructions	1
Fuses 1.5A (Protection)	2
Fuse 1A (for 5-line voltage model only)	1
Fuses 2A (for 5-line voltage model only)	2

## NOTE:

*Specifications and the design subject to possible modification without notice due to improvements.*

## 2. CONNECTION DIAGRAM

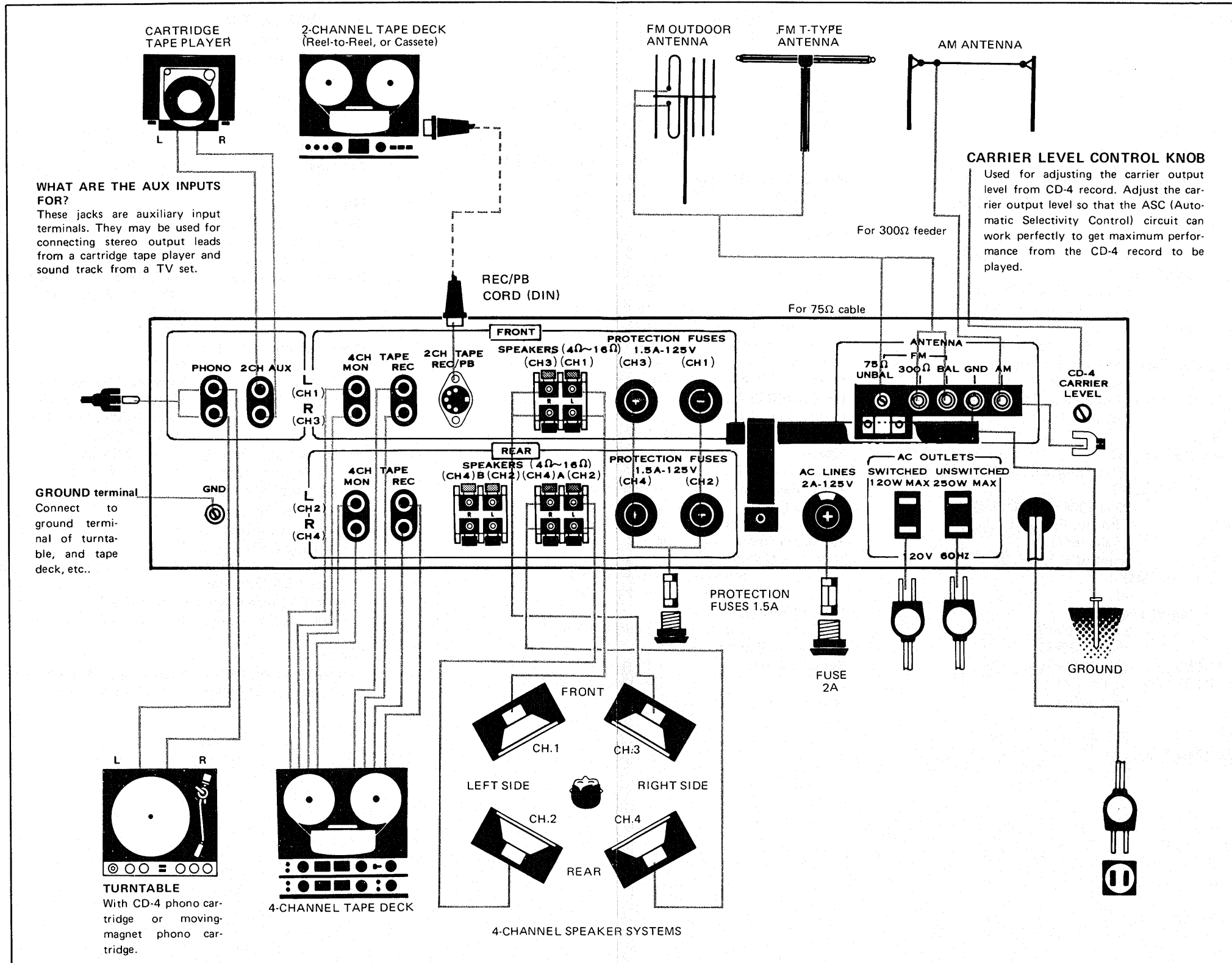

### 3. FRONT PANEL FACILITIES

**CD-4 INDICATOR LAMP**

This lights up, indicating that the CD-4 disc record is now being played (only when the MODE switch is set at 4CH CD-4).

**CD-4 SEPARATION CONTROL (FRONT and REAR) KNOBS**

For playing a CD-4 disc record with an exclusive CD-4 phono cartridge, adjust channel separation between FRONT and REAR.

After this adjustment once made, with the CD-4 phono cartridge, 2-channel disc record reproduction is possible, too.

As far as reproduction of any stereo disc record with a 2-channel phono cartridge is concerned, always turn the LEFT and RIGHT knobs to central positions.

**LEFT knob:** Adjusts separation between FRONT (CH.1) and REAR (CH.2) for LEFT channel.

**RIGHT knob:** Adjusts separation between FRONT (CH.3) and REAR (CH.4) for RIGHT channel.

**NOTE:**

Never fail to re-adjust the CD-4 SEPARATION CONTROL knobs whenever replacement with a new phono cartridge or stylus is made.

**POWER SWITCH**

Turns the power on and off. Also controls the power to the SWITCHED auxiliary AC outlet on the rear panel.

**SPEAKERS SWITCH**

**SPEKR :** Switches all speakers on and off. Button pushed - OFF; button released - ON. Use position OFF when listening through headphones.

**REAR :** Two pairs of rear speakers (pair A and pair B) can be connected and selected with this switch. Button pushed - rear speakers B operations; button released - rear speakers A operating.

**NOTE:**

Always turn the VOLUME down to minimum before operating these speaker switches.

**PHONES JACK**

Accepts a pair of low impedance stereo headphones. Only the front channels (front left and front right channels) are heard through the headphones.

**MODE INDICATOR LAMPS**

These light up in accordance with the position of the MODE switch.

**FM STEREO INDICATOR LAMP**

Lights up when an FM stereo broadcast is being received.

**SIGNAL METER**

For easy, precise tuning on AM and FM, maximum deflection means optimum tuning condition. Also helpful for finding the optimum position of the AM or FM antenna.

**PROGRAM INDICATOR LAMPS**

Light up in accordance with the position of the FUNCTION switch.

**TUNING KNOB**

For tuning in AM and FM stations.

**MODE SWITCH**

This switch sets the desired mode; 2-channel stereo, matrix 4-channel, discrete 4-channel (CD-4).

**2CH :** Conventional 2-channel stereo reproduction. No sound is heard from the rear speaker systems.

**4CH CD-4 :** For playing discrete 4-channel CD-4 records.

Also for playing discrete 4-channel stereo programs such as reel-to-reel tapes and Quad 8 tape cartridges.

Used for listening to 2-channel program sources, too. Sound heard from the left rear speaker (CH. 2) will be the same as that from the left front speaker (CH. 1), while sound from the right rear speaker (CH. 4) will be the same as that from the right front speaker (CH. 3).

**RM :** Used for 4-channel reproduction of RM (regular matrix) records, or FM stereo broadcasts playing RM matrix records.

Also use this position when listening to 2-channel tapes, records and FM stereo broadcasts, adding 4-channel effects.

**SQ :** Used for 4-channel reproduction of SQ matrix record or FM stereo broadcasts playing SQ matrix records.

Also use this position when listening to 2-channel records and FM stereo broadcasts, adding 4-channel effects.

**FUNCTION SWITCH**

This switch selects the program sources.

**AM :** For AM radio reception.

**FM MONO :** For FM monophonic reception only. Use this position only for receiving weak or noisy FM stations. Note that in this position FM stereo broadcasts will also be received in monophonic mode, even though the stereo indicator lights up.

**FM AUTO :** Usual FM reception, with automatic switching depending on whether the broadcast is stereophonic or monophonic.

**PHONO :** For record playing.

**AUX :** For playing signals fed to the AUX jacks.

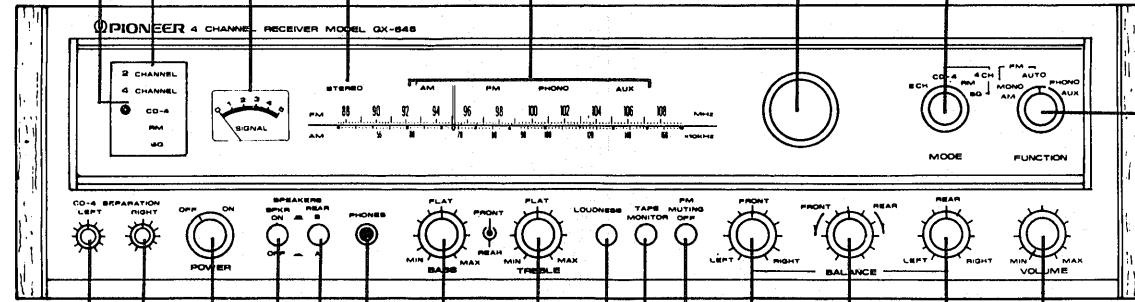

**BASS & TREBLE CONTROLS**

Used for adjusting bass and treble. Clockwise (counterclockwise) turning of these controls from the FLAT positions will boost (diminish) tone. Also, only the front (rear) channel can be adjusted by turning the front (rear) part while the other part is being held. For normal listening, set them to the FLAT positions.

**LOUDNESS SWITCH**

For a more natural sound spectrum at low listening volume, push this button. Extreme low and very high sounds will be somewhat boosted. The loudness circuit acts on all four channels.

**TAPE MONITOR SWITCH**

Push this button only when playing (or monitoring) tapes with the tape deck connected to the TAPE MON and REC input or the REC/PB connector. In all other operation modes (PHONO, FM, AM, AUX), leave the button in off position, i.e. released. No sound is heard if this button is pushed when it shouldn't be.

**FM MUTING SWITCH**

In released position, the FM muting circuit cancels out noise on unused FM signals ("inter-station noise"), but it also rejects very weak, faint FM stations. To receive such a station, push the button to turn off the FM muting circuit.

**FRONT BALANCE CONTROL**

Controls the level balance of front speaker systems. Turning the control to the right (clockwise) from the center will decrease the sound of the left-side speaker systems, and turning it to the left (counterclockwise) will decrease the sound of the right-side speaker systems.

**FRONT - REAR BALANCE CONTROL**

Controls the level balance between the speaker systems in front and rear speaker systems. Turning the control to the right (clockwise) from the center will decrease the sounds of the front-side speaker systems, and turning it to the left will decrease the sounds of the rear-side speaker systems.

**REAR BALANCE CONTROL**

Controls the level balance of rear speaker systems. Turning the control to the right (clockwise) from the center will decrease the sound of the left-side speaker systems, and turning it to the left (counterclockwise) will decrease the sound of the right-side speaker systems.

**VOLUME CONTROL**

Controls the output volumes of all four channel signals simultaneously. Turning the knob to the right (the left) will increase (decrease) the volume.

# 4. BLOCK DIAGRAM

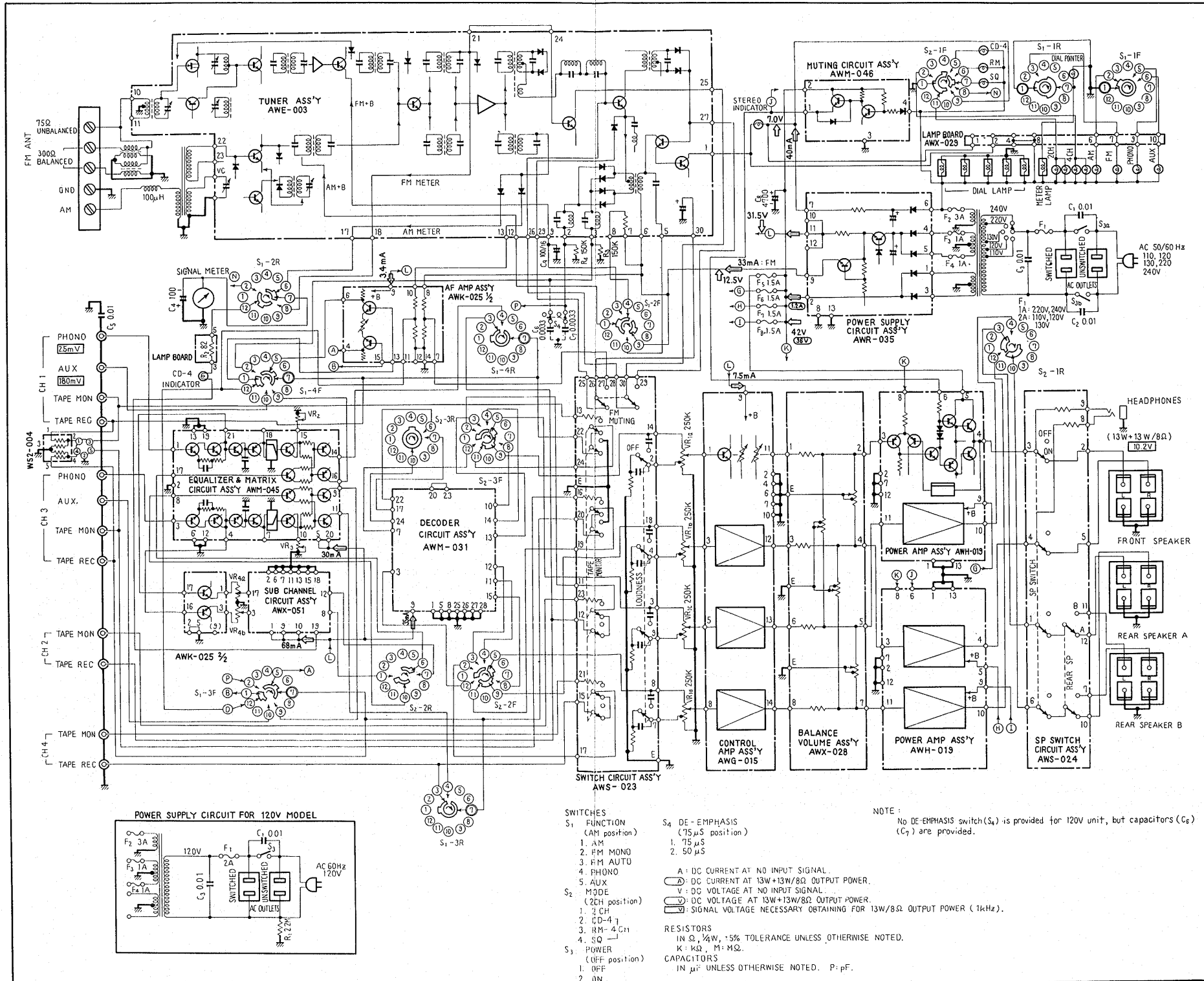

- SWITCHES**
- S<sub>1</sub> FUNCTION (AM position)**
1. AM
  2. FM MONO
  3. FM AUTO
  4. PHONO
  5. AUX
- S<sub>2</sub> MODE (2CH position)**
1. 2CH
  2. CD-4
  3. RM-4 C1
  4. SQ
- S<sub>3</sub> POWER (OFF position)**
1. OFF
  2. ON
- S<sub>4</sub> DE-EMPHASIS (75 μS position)**
1. 75 μS
  2. 50 μS

A: DC CURRENT AT NO INPUT SIGNAL.  
 ⊙: DC CURRENT AT 13W+13W/8Ω OUTPUT POWER.  
 V: DC VOLTAGE AT NO INPUT SIGNAL.  
 ⊕: DC VOLTAGE AT 13W+13W/8Ω OUTPUT POWER.  
 ⊖: SIGNAL VOLTAGE NECESSARY OBTAINING FOR 13W/8Ω OUTPUT POWER (1kHz).

**RESISTORS**  
 IN Ω, ¼W, ±5% TOLERANCE UNLESS OTHERWISE NOTED.  
 K: kΩ, M: MΩ.

**CAPACITORS**  
 IN μF UNLESS OTHERWISE NOTED. P: pF.

**NOTE:**  
 No DE-EMPHASIS switch (S<sub>4</sub>) is provided for 120V unit, but capacitors (C<sub>6</sub>, C<sub>7</sub>) are provided.



# 5. PARTS AND P.C. BOARD LOCATION

## 5.1 TOP VIEW

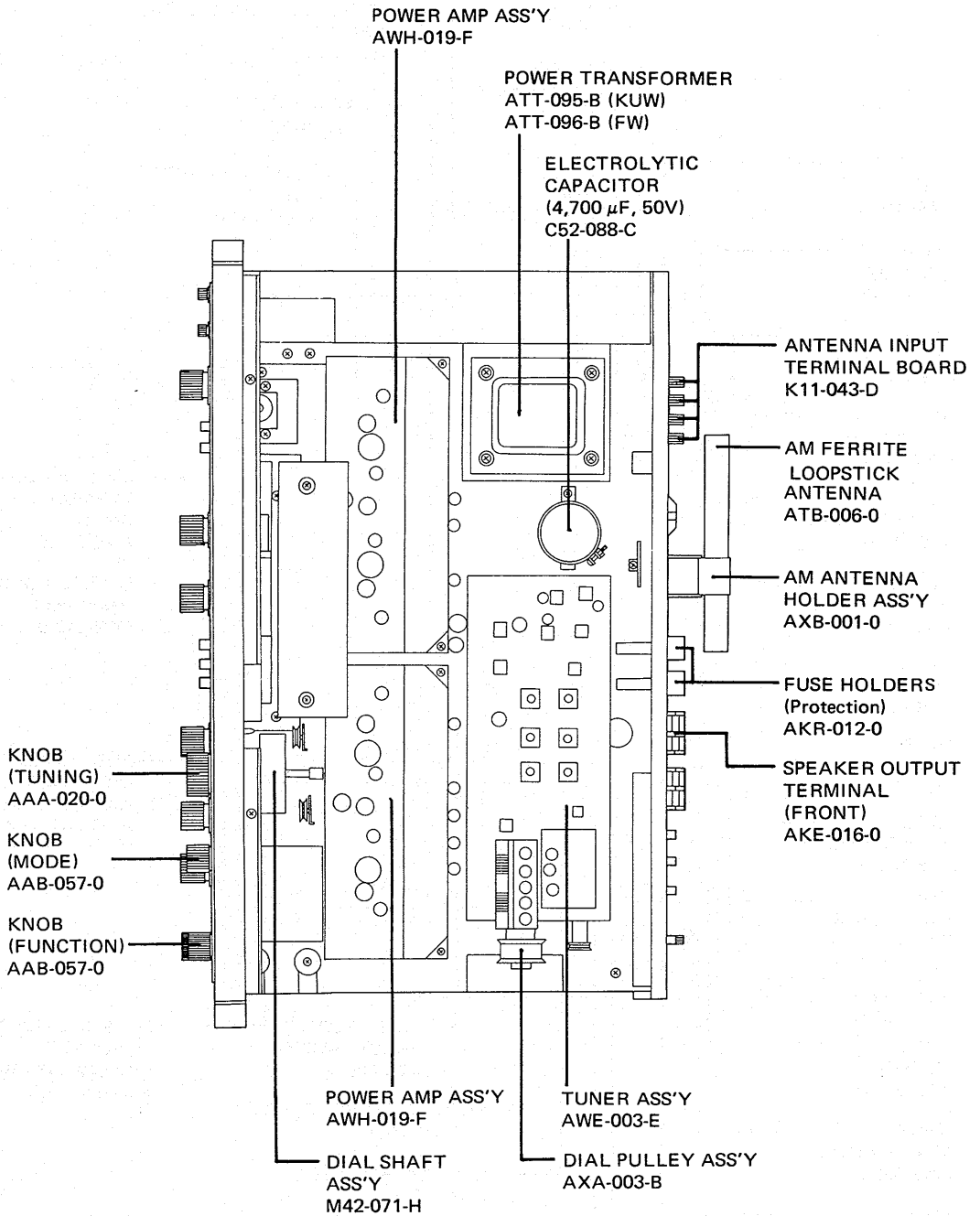

## 5.2 BOTTOM VIEW

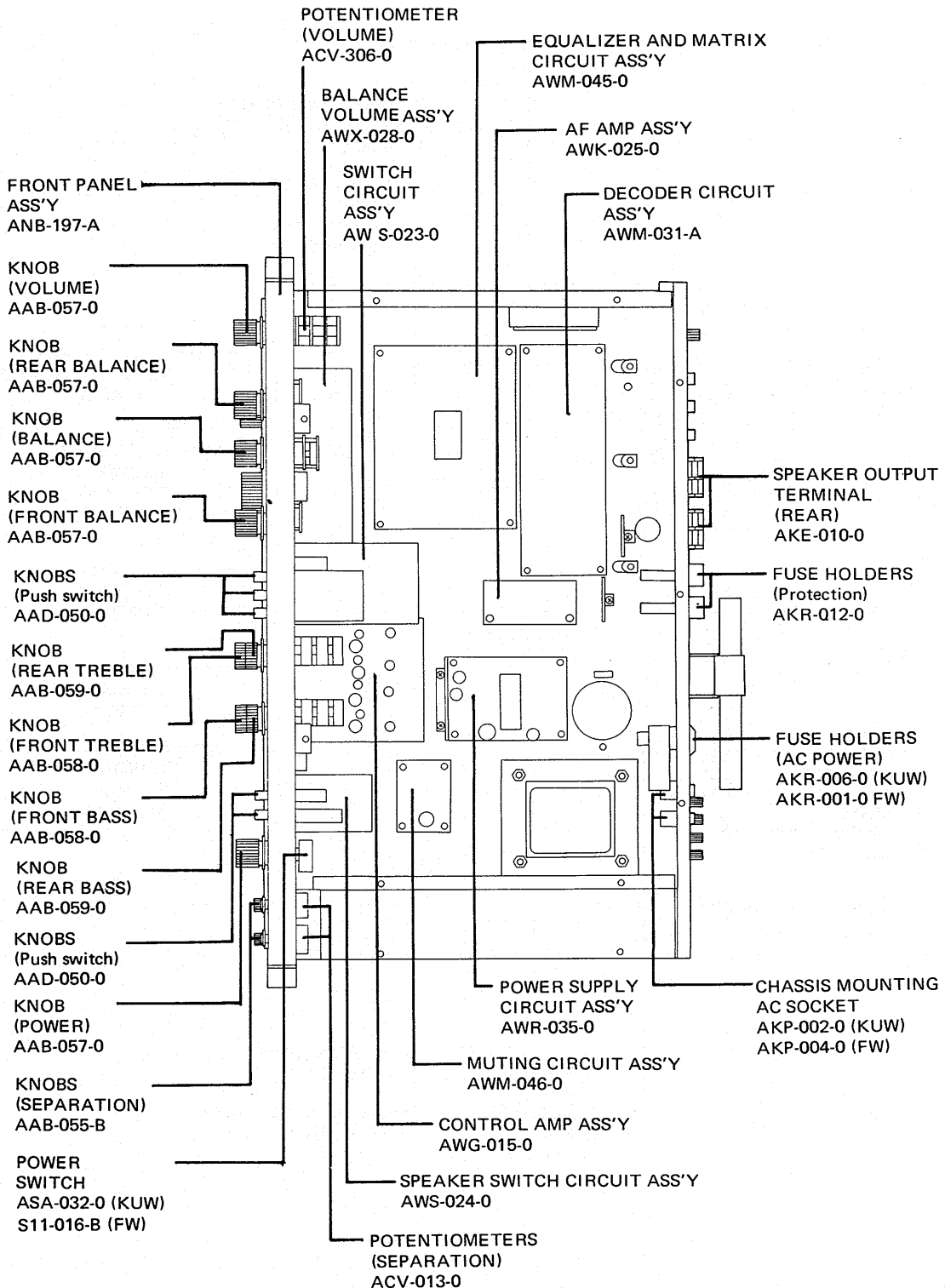

## 6. DISASSEMBLY

1. Remove 4 screws from the both sides of the wooden case
2. Pull off all knobs, then remove nuts and washers from shafts.
3. Remove 2 screws from top of front panel as illustrated in figure. The front panel can now be removed.
4. The bottom plate can be removed after loosening 11 screws.

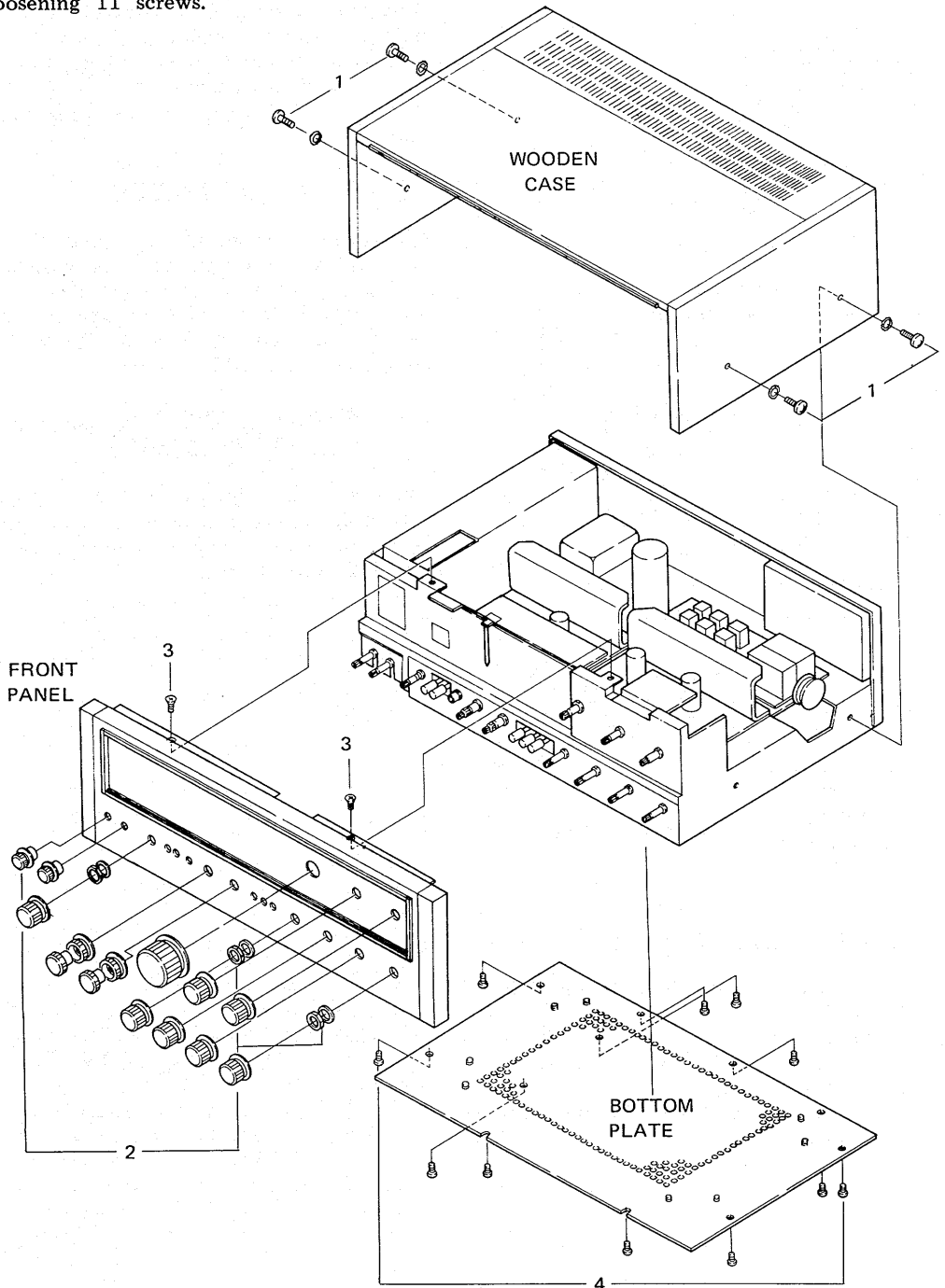

# 7. SIGNAL PATH AND CIRCUIT FUNCTIONS

## 7.1 RECORDING AND PLAYBACK OF CD-4 DISCS

The CD-4 disc is a recent development. Being a "Discrete" 4-channel medium, it features excellent channel separation when played over suitable 4-channel equipment, but can also be played as a conventional 2-channel stereo record.

Fig. 1 shows the configuration of signals present in a CD-4 record.

Each of the two sub-signals occupies a frequency modulated supersonic carrier with a center frequency of 30kHz.

The sub-signal conveys the "Front-Rear" difference information.

The main signals are recorded as in a conventional stereo record, occupying the 30Hz ~ 15kHz audio band and conveying the "Front+Rear" sum information.

From these sum and difference signals, the original 4 channel signals are retrieved in a series of algebraic operations performed in the demodulator:

$$(L_f + L_r) + (L_f - L_r) = 2L_f$$

$$(L_f + L_r) - (L_f - L_r) = 2L_r$$

$$(R_f + R_r) + (R_f - R_r) = 2R_f$$

$$(R_f + R_r) - (R_f - R_r) = 2R_r$$

where "R" stands for Right, "L" for Left, "f" for front, "r" for rear.

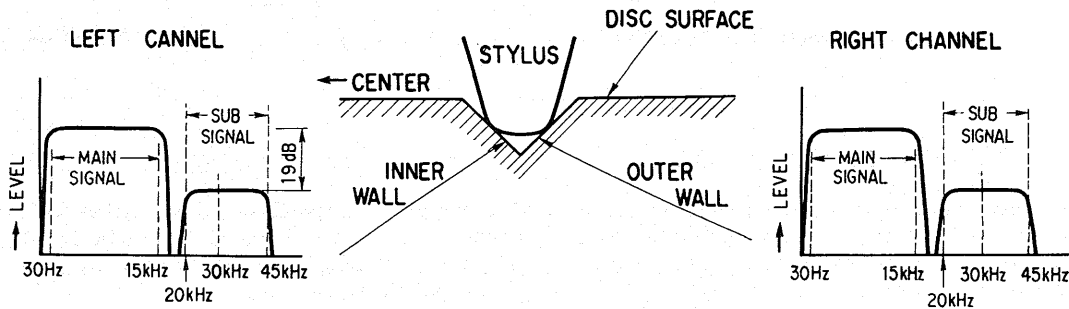
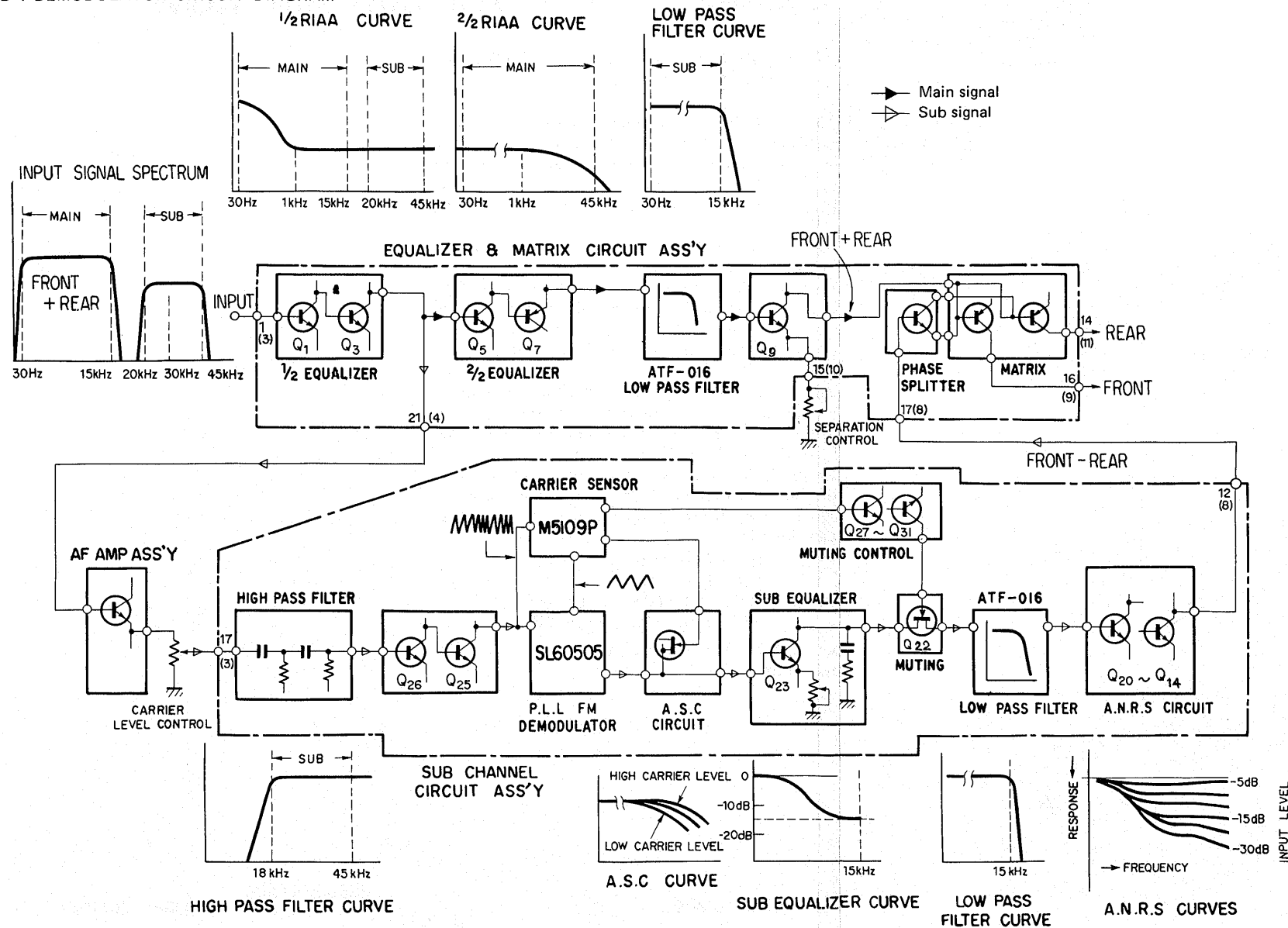

Fig. 1

CD-4 DEMODULATOR CIRCUIT DIAGRAM



7.2 1/2 EQUALIZER (Q1, Q3)

The signal picked up by the phono cartridge from a CD-4 record is a combination of main and sub components, covering a total bandwidth from 30Hz to 45kHz.

A conventional RIAA equalizer would greatly attenuate the spectrum above 20kHz (occupied by the sub signals) and would render reproduction of this range impossible.

For this reason, only the range below 1kHz is subjected to RIAA equalization in the CD-4 demodulator, while the range above 1kHz is amplified flat.

The circuit that performs this partial RIAA equalization is called the 1/2 equalizer fed, whose output signal is to the 2/2 equalizer and the AF amplifier assembly.

7.3 2/2 EQUALIZER (Q5, Q7)

This circuit performs RIAA equalization of the above 1 kHz range.

The combined effect of 1/2 and 2/2 RIAA equalization results in standard RIAA parameters, as shown in fig. 2.

From the 2/2 equalizer, the signal passes on to the low pass filter.

7.4 LOW PASS FILTER (In Main Signal Path)

With a cut-off frequency of 15kHz, removing the sub signal (20kHz to 45kHz range) and passing only the main signal component.

7.5 AF AMPLIFIER ASSEMBLY

The output signal from the 1/2 RIAA equalizer, still containing the sub signal components, undergoes a drop in impedance in the Q1 emitter follower circuit and can then be attenuated to any desired level by the carrier level control potentiometer.

The signal then enters the sub channel circuit assembly.

7.6 HIGH PASS FILTER

With a cut-off frequency of 18kHz, this high pass filter removes the main signal components, passing only the supersonic sub signal.

After amplification, this then enters the phase locked loop type FM detector (SL60505) and the carrier sensor IC (M5109P).

7.7 PHASE LOCKED LOOP FM DETECTOR (SL60505)

This circuit demodulates the (FM modulated) sub signal, producing an audio signal as output. This audio signal constitutes the front-minus-rear difference information.

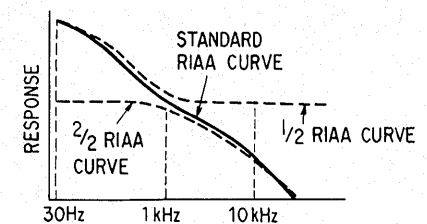

Fig. 2

### 7.8 AUTOMATIC SELECTIVITY CONTROL

This circuit is a high cut filter of variable cut-off frequency which is controlled by the carrier level. Assume that a rather worn CD-4 record is being played. As this will produce only a low (or no) sub carrier level, the high range of the audio signal after demodulation will suffer from noise.

To make this noise inaudible, the ASC automatically reduces higher range frequency response whenever the carrier level is insufficient.

### 7.9 SUB EQUALIZER (Q23)

In the interest of better signal-to-noise ratio, the sub signals have undergone a high-range preemphasis in the recording process.

To obtain flat frequency response, the sub signal must therefore pass through this equalizer circuit in playback.

### 7.10 LOW PASS FILTER (In Sub Signal Path)

The demodulated sub signal also passes through a low pass filter with a cut-off frequency of 15kHz where any remaining high frequency carrier signal is removed.

### 7.11 AUTOMATIC NOISE REDUCTION SYSTEM (Q20 ~ Q14)

In the recording, high level (loud) signals are recorded with flat frequency response, while low level (soft) passages are electronically boosted in their medium and high frequency ranges.

This means that on a CD-4 disc, the dynamic range in the medium and high areas of the sound spectrum is compressed.

To recover the original dynamic range, the signal passes through the ANRS circuit in the demodulator.

The result of this cycle of compression (in recording) and expansion (in playback) of the dynamic range is better signal-to-noise ratio.

The ANRS circuit assembly consists of: medium-high range attenuator, medium-high range booster, high pass filter, band pass filter and control amplifier.

A.N.R.S. CIRCUIT SCHEMATIC

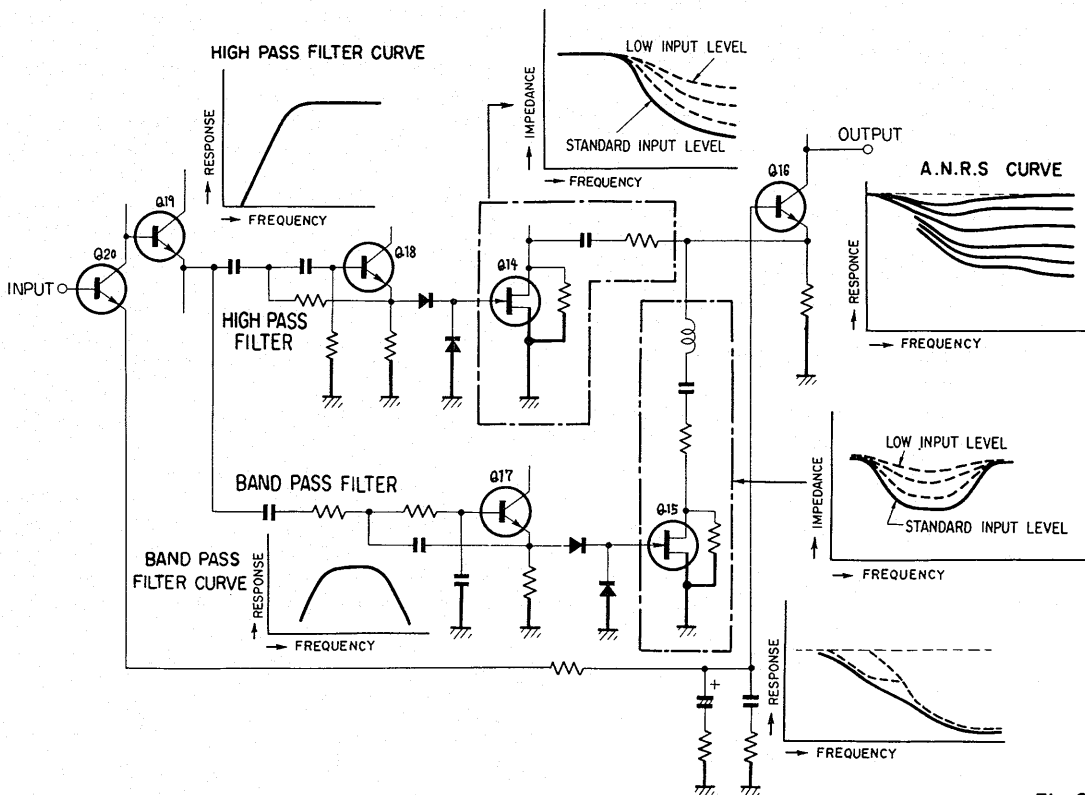

Fig. 3

The medium-high range booster is a variable gain circuit, its gain being controlled by the control amplifier. Assuming that the input signal has standard level in the medium-high frequency range, attenuator and booster circuits will display practically inverse frequency characteristics, resulting in flat overall response. With a low-level signal, the attenuation effect will be more pronounced than the boosting effect, resulting in an attenuation of the signal. The circuit is thus very similar in its function to the Dolby\* noise reduction system employed in tape recording.

After passing through the ANRS circuit, the signal enters the phase splitter.

\* Dolby is a trademark of Dolby Laboratories, Inc.

## 7.12 PHASE SPLITTER

In the phase splitter, the sub signal is divided into two portions of opposite phase: + (Front - Rear) and, with a 180° phase rotation, - (Front - Rear).

This is required for the subsequent matrixing operation.

## 7.13 SEPARATION CONTROL (Q9)

By controlling the level of the main signal, this circuit matches main and sub signal levels. This matching is required in order to obtain the desired results in the algebraic (matrix) operations described on page 14.

Signals of different levels would not yield the specified results, causing a deterioration in channel separation.

## 7.14 MATRIX CIRCUIT

The algebraic (matrix) operations whereby the four original channels are retrieved, are performed in this circuit.

Identical matrixing is performed for either (left and right) side:

$$(\text{Front} + \text{Rear}) + (\text{Front} - \text{Rear}) = 2 \text{ Front}$$

$$(\text{Front} + \text{Rear}) - (\text{Front} - \text{Rear}) = 2 \text{ Rear.}$$

## 7.15 MUTING CIRCUIT (M5109P, Q27 ~ Q31, Q22)

Located in the sub signal path between sub equalizer and low pass filter, the muting circuit functions in a similar way as those often provided in FM tuners.

When, because of dust or scratches in the record groove, no sub carrier (30kHz) is momentarily present, noise is generated.

To prevent this noise from being heard, the output signal of the sub signal demodulator must be momentarily interrupted.

The muting circuit performs this function by detecting the presence or absence of the 30kHz carrier and turning the demodulator output ON and OFF accordingly.

The muting circuit assembly consists of carrier sensor, switching control circuit and gate circuit.

The CD-4 indicator lamp circuit is incorporated in the switching control section.

The CD-4 indicator lamp thus goes off when no or only insufficient sub carrier is detected.

## 8. ALIGNMENT PROCEDURE

### REQUIRED INSTRUMENTS

- FM/AM Signal generator.
- FM/AM Sweep generator: Center frequency 10.7 MHz, 455 kHz
- Oscilloscope
- AC VTVM
- FM multiplex signal generator preferably with RF output.

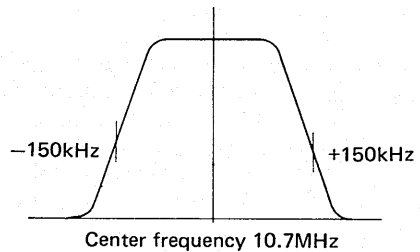

Fig. 4

### 8.1 FM/AM IF ALIGNMENT

#### ● FM SECTION

- a) Connect a 0.01 $\mu$ F capacitor between TP1 and ground before the alignment.
- b) Connect a 220k $\Omega$  resistor in series with the vertical input terminal of the oscilloscope.
- c) Remove the meter lead from terminal 18, then terminate a 4.7k $\Omega$  resistor between terminal 18 and ground.
- d) Connect the vertical input to terminal 18.
- e) Set the selector switch to FM MONO.
- f) Connect the output lead of the sweep generator to the FM antenna terminals.
- g) Set the output level of the sweep generator to 85dB.
- h) Adjust the primary and secondary cores of T6 to obtain a symmetrical pattern.
- i) Set the output level of the sweep generator to 65dB.
- j) Adjust the cores of T4 and T5 for maximum gain and symmetry of the pattern.
- k) Vary the output level of the sweep generator from 60dB to 90dB, then keep the top of the pattern flat and make sure that the center frequency does not drift. If it drifts, repeat steps (g) to (j).
- l) Remove the capacitor (4.7 $\mu$ F) from terminal 28.
- m) Disconnect the vertical input from terminal 18, then reconnect it to TP1.
- n) Set the output level of the sweep generator to 70dB.
- o) Observe the S-curve pattern when adjusting the cores of T7. (Linearity is improved by the primary core; symmetry by the secondary core).
- p) Disconnect the 0.01 $\mu$ F capacitor from TP1 after the alignment has been completed.
- q) Connect the capacitor (4.7 $\mu$ F) to terminal 28 after the alignment has been completed.

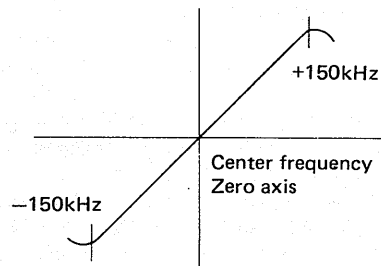

Fig. 5

#### ● AM SECTION

- a) Turn the selector switch to AM.
- b) Connect the output lead of the sweep generator to the AM antenna terminal.
- c) Connect the vertical input of the oscilloscope to the TAPE REC jack.
- d) Set the output level of the sweep generator to 40dB.
- e) Adjust the IFT cores (T9, T10, T11) as shown in Fig. 6, for maximum gain and symmetrical pattern.

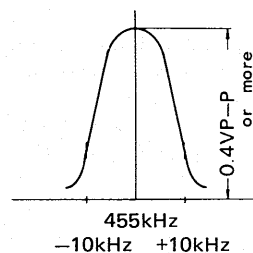

Fig. 6



## 8.2 FM/AM TRACKING ALIGNMENT

### ● FM SECTION

- a) Turn the selector switch to FM MONO.
- b) Connect the output leads of the FM signal generator to the FM antenna terminals.
- c) Set the FM signal generator to modulation 400Hz, 100% and output level 12dB, frequency 90MHz; also the receiver dial at set 90MHz.
- d) Connect the VTVM and oscilloscope (in parallel) to the TAPE REC jack.
- e) Observing the output level on the VTVM, adjust the following cores for maximum reading on the meter.  
T3 . . . . . Oscillator circuit  
T1 . . . . . Antenna circuit  
T2 . . . . . RF circuit
- f) Set the frequency of the FM signal generator and the receiver dial to 106MHz.
- g) Adjust as follows:  
Trimmer capacitor CT3 . . Oscillator circuit  
Trimmer capacitor CT1 . . . Antenna circuit  
Trimmer capacitor CT2 . . . . . RF circuit
- h) Repeat steps (e) to (g) a few times.
- i) Set the output level of the FM signal generator to maximum signal meter deflection.
- j) Adjust the primary core of T7 for minimum sound distortion.

### ● AM SECTION

- a) Turn the selector switch to AM.
- b) Connect the AM signal generator to the AM antenna terminal.
- c) Set the AM signal generator to modulation 400Hz, 30%, output level 30dB, frequency 600kHz. Set the receiver dial at 600kHz.
- d) Connect the VTVM and oscilloscope (in parallel) to the TAPE REC jack.
- e) Observing the output level on the VTVM, adjust the following cores for maximum reading.  
T8 . . . . . Oscillator circuit  
Ferrite loopstick antenna . . Antenna circuit
- f) Set the AM signal generator and the receiver dial to 1,400kHz.
- g) Observing the output level on the VTVM, adjust the following trimmer capacitors for maximum reading.  
CT5 . . . . . Oscillator circuit  
CT4 . . . . . Antenna circuit
- h) Repeat alignments (e) to (g) a few times.
- i) After these alignments, lock the trimmer capacitor with paint.

## 8.3 MPX DECODER ALIGNMENT

- a) Modulate the FM signal generator output by FM MPX modulator.
- b) Turn the selector switch to FM AUTO.
- c) Connect the FM signal generator to the FM antenna terminals.
- d) Set the FM MPX modulator to modulation; main 1kHz (L + R) 100%, pilot 10%.
- e) Set the output level of the FM signal generator to 60dB.
- f) Turn the tuning knob to maximum reading on the signal meter.
- g) Set the modulation of the FM MPX modulator to pilot only.
- h) Connect the oscilloscope to TP2.
- i) Adjust the transformers (T13, T14, T15) until the output level of the 19kHz becomes maximum on the scope.
- j) Set the FM MPX modulator to pilot with L or R signal.
- k) Connect the oscilloscope and VTVM to the TAPE REC jacks.
- l) Adjust the semi-fixed potentiometer on the AF amp Ass'y (AWK-025) until the output level of the L or R signal becomes maximum on the scope.

TUNER ASS'Y (AWE-003)

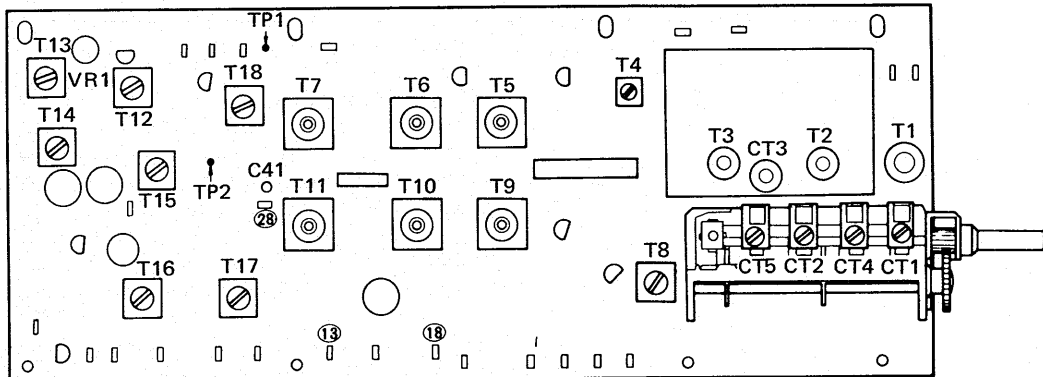

## 8.4 OTHER ALIGNMENTS

### ● CHECKING THE SCA FILTER

- a) Connect the FM signal generator to the FM antenna terminals.
- b) Modulate the FM signal generator connected to the audio generator, check that the frequency response shows troughs at around 67kHz and 72kHz.
- c) Should the item (b) give the unsatisfactory result, adjust T18 and T12.

### ● CHECKING THE STEREO INDICATOR

- a) Connect the FM signal generator to the FM antenna terminals.
- b) Turn the selector switch to FM AUTO.
- c) Modulate the FM signal generator connected to the FM MPX modulator, and set the FM MPX modulator pilot on. Check that the stereo indicator lamp goes in, then set the FM MPX modulator to pilot off, and check that the stereo indicator lamp goes out.

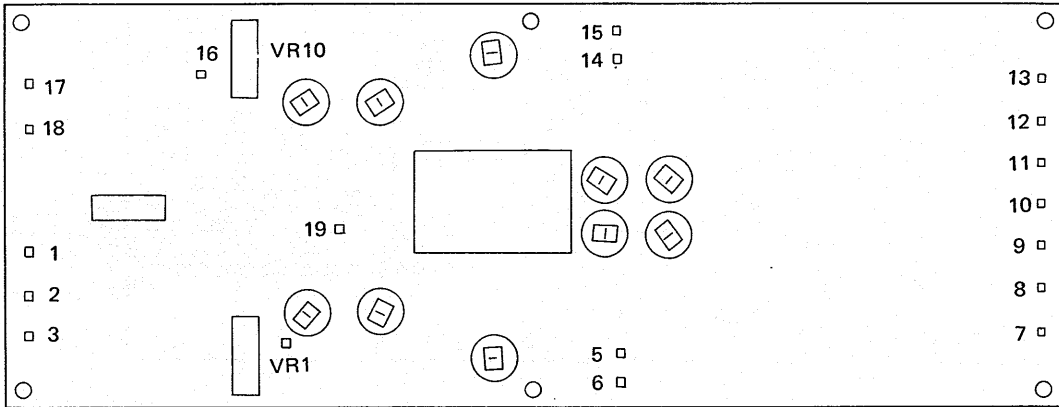

### 8.5 ADJUSTMENT OF PHASE LOCKED LOOP OSCILLATION FREQUENCY

When IC SL60505 has been replaced, VR1 (VR10) must be re-adjusted. VR1 (VR10) controls the oscillation frequency of the phase locked loop demodulator.

The adjustment procedure described below is somewhat coarse but should yield satisfactory results even without measuring instruments if performed carefully.

Please note that the adjustment cannot be performed with a worn stylus or CD-4 record.

#### ● REQUIRED INSTRUMENTS

- New phono cartridge suitable for CD-4 tracking
- New CD-4 test record (PQX-1011)
- Oscilloscope

#### ● PROCEDURE

- a) Ground terminal No. 19 to defeat muting function.
- b) Connect oscilloscope to terminal No. 14.
- c) Turn carrier level control (on rear panel) to maximum.
- d) Play band 1 of test record PQX-1011.
- e) The oscilloscope shows a warble tone signal.  
Turn back the carrier level control until a point can be found where the warble pattern becomes deformed. Adjust VR10 so that the deformed waveforms grow changed into undeformed waves.  
Repeat these steps several times.
- f) Now connect oscilloscope to terminal No. 5.
- g) Turn carrier level control to maximum again.
- h) Play band 2 of test record PQX-1011.
- i) Adjust VR1 in the same way as in step e, above.

### 8.6 CARRIER LEVEL ADJUSTMENT

- a) Turn up volume to average listening level.
- b) Play the Band 4 to adjust a 30kHz carrier level from the test record. "Signal For 30kHz Carrier Level Adjustment."
- c) Listening to the signal (400Hz), turn the Carrier Level Control knob of the QX-646 on the rear panel from the right (maximum position) to the left.
- d) Turning the Carrier Level Control knob to the left, find the changing point of tone quality, at which the signal becomes distorted. Then turn to the right to let the knob adjust at a turning angle of between  $15^{\circ}$ ~ $30^{\circ}$

Once the final carrier adjustment is made, the knob must not be turned except for readjustment after replacement of phono cartridge or stylus, and after a long period of play.

## 9. DIAL CORD STRINGING

1. Set the tuning capacitor to maximum capacitance.
2. Tie one end of the string to the hook on the side of the tuning pulley, then lead it to the arrow-indicated direction shown in the figure.
3. Wind the string 1/2 turn around the tuning pulley, then lead it to the small pulleys A, B, and C in order.
4. Wind the string 3 turns around the tuning shaft, then lead it to the small pulleys D and E.
5. Lead the string to the small pulley F, then wind it 2 turns around the tuning pulley.
6. Finally, tie the end of the string to the spring on the tuning pulley.
7. Tune receiver to low end. Fasten dial pointer to string so that it indicates low end on dial scale.

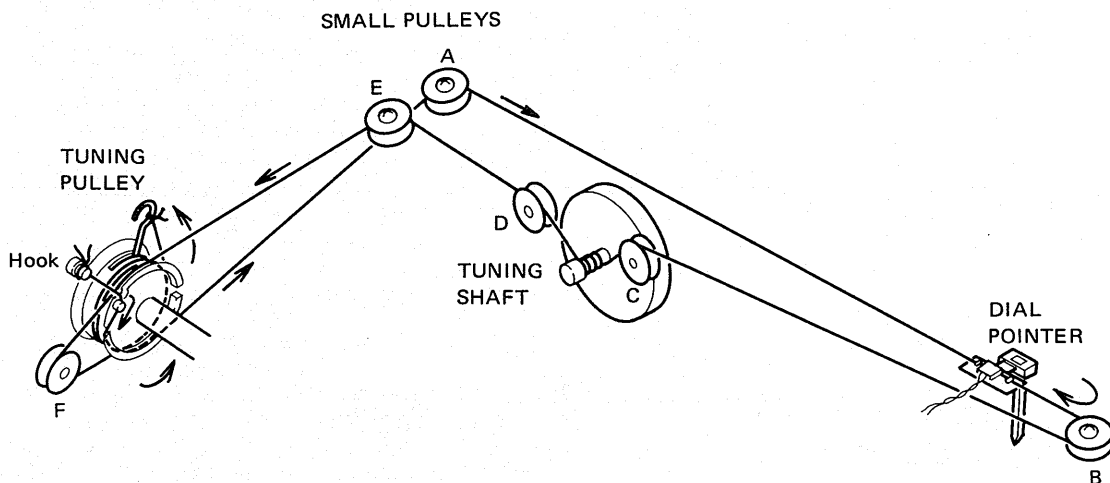

# 10. LEVEL DIAGRAM

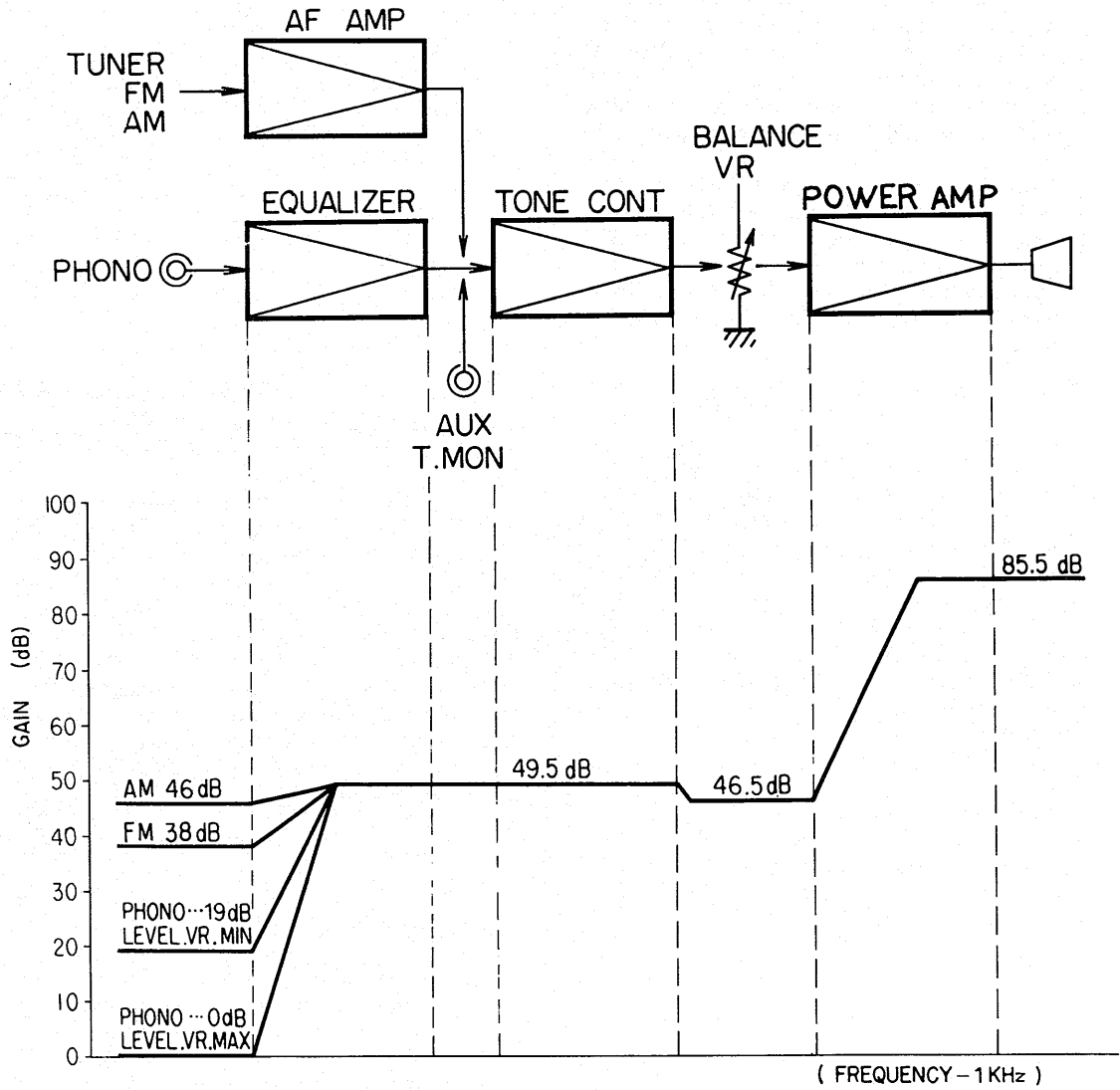

# 11. EXPLODED VIEW AND PARTS LIST

**NOTICE:**

Any parts asterisked\* are subject to being not supplied.

## Parts List of Exploded View

Key No.	Description	Part No.	
1	Color-plated wide shoulder screw	ABA-010-A	
2	Wooden case	AMM-025-A	
3	External tooth lock washer	B-21-011-0	
4	Power amplifier assembly	AWH-019-F	
5*	Wire supporter	M45-105-C	
6	Tuner assembly	AWE-003-E	
7*	Shield cover (Rear)	ANH-097-A	
8*	Wire cover	ANK-026-A	
9	Lamp board assembly	AWX-029-0	
10*	Lamp box	ANH-095-0	
11	Power transformer	ATT-095-B	KUW model
	Power transformer	ATT-096-B	FW model
12*	Selector cover	ANH-096-0	
13	Electrolytic capacitor 4,700 $\mu$ F 50V	C52-088-C	
14*	P.C. Board holder	AEB-019-0	
15*	Side plate	ANK-042-0	
16	Sub channel circuit assembly	AWX-051-A	
17	Antenna input terminal board	K11-043-D	
18	Speaker output terminal (Front)	AKE-016-0	
19	Phono jack-A (4 jacks)	AKB-014-0	
20	Phono jack-B (4 jacks)	AKB-015-0	
21*	Model name plate	AAL-154-0	KUW model
	Model name plate	AAL-159-0	FW model
22	AM ferrite loopstick antenna	ATB-006-0	
23	AM antenna holder assembly	AXB-001-0	
24	Potentiometer (SEPARATION)10k-C	ACV-013-0	
25*	Mode indicater	ANK-044-0	
26*	Pilot lamp bracket	AEB-040-0	
27	Lamp (Mode indicator)	AEL-007-0	
28	Potentiometer (CARRIER LEVEL CONTROL)10k-B	ACT-108-0	
29*	Volume holder	ANF-133-0	
30*	Sub chassis	ANA-045-A	
31	Terminal strip (2P)	AKC-018-0	
32	Cord grommet	AEC-079-0	
33	AC power cord	ADG-003-0	KUW model
	AC power cord	D11-002-B	FW model
34	Cord grommet	AEC-079-0	
35	Fuse holder (Protection)	AKR-012-0	
36	5P connector (DIN type)	K93-003-B	
37	Signal meter	AAW-003-0	
38	Lamp (Signal meter)	E22-032-0	
39	Fuse holder (1P)	K91-005-A	
40*	Meter held metal	ANG-066-0	
41*	Sub panel	AND-061-A	

Key No.	Description	Part No.	
42*	Rear panel	ANC-084-A	
43	Binding post (Ground)	AKE-012-A	
44	Front panel assembly	ANB-197-A	
45	Spacer	AEC-090-0	
46	Spacer	AEC-090-0	
47	Dial pointer	AAF-020-0	
48	Dial scale	AAG-048-B	
49*	Chassis	ANA-044-A	
50	Phono jack -A (4 jacks)	AKB-014-0	
51	Knob (SEPARATION)	AAB-055-B	
52	Double knob (Inner)	AAB-058-0	
53	Double knob (Outer)	AAB-059-0	
54	Knob (TUNING)	AAA-020-0	
55	Knob (Others)	AAB-057-0	
56	AC socket holder	M49-127-A	KUW model only
57	Chassis mounting AC socket	AKP-002-0	KUW model
	Chassis mounting AC socket	AKP-004-0	FW model
58	Fuse holder (AC power)	AKR-006-0	KUW model
	Fuse holder (AC power)	AKR-001-0	FW model
59	Terminal strip (4P)	AKC-016-0	
60	Electrolytic capacitor 100 $\mu$ F 16 V	CEA 101P 16	
61	Fuse 3A (Protection)	AEK-003-0	KUW model
	Fuse 3A (Protection)	E21-022-0	FW model
62	Terminal strip (4P)	AKC-016-0	
63	Fuse 1A (Protection)	AEK-004-0	KUW model
	Fuse 1A (Protection)	E21-020-0	FW model
	Fuse 1A (Protection)	AEK-004-0	KUW model
64	Fuse 1A (Protection)	E-21-022-0	FW model
65	Dial shaft assembly	M42-071-H	
66	Selector switch (MODE)	ASC-050-A	
67	Selector switch (FUNCTION)	ASC-049-B	
68	Terminal strip (4P)	AKC-016-0	
69	Speaker output terminal (Rear)	AKE-010-0	
70	AF amplifier assembly	AWK-025-0	
71	Decoder circuit assembly	AWM-031-A	
72	Power switch	ASA-032-0	KUW model
	Power switch	S11-016-B	FW model
73	Speaker switch circuit assembly	AWS-024-0	
74	Headphone jack	K72-026-0	
75	Muting circuit assembly	AWM-046-0	
76	Control amplifier assembly	AWG-015-0	
77	Power supply circuit assembly	AWR-035-0	
78	Switch circuit assembly	AWS-023-0	
79	Potentiometer (VOLUME) 250K-B <sub>1</sub>	ACV-306-0	
80	Balance volume assembly	AWX-028-0	
81	Equalizer and matrix circuit assembly	AWM-045-0	
82*	Bottom plate	ANE-028-0	
83*	Mode indicater held metal	ANF-135-0	
84	Knob (Push)	AAD-050-0	
85	Coil spring	AEF-002-B	

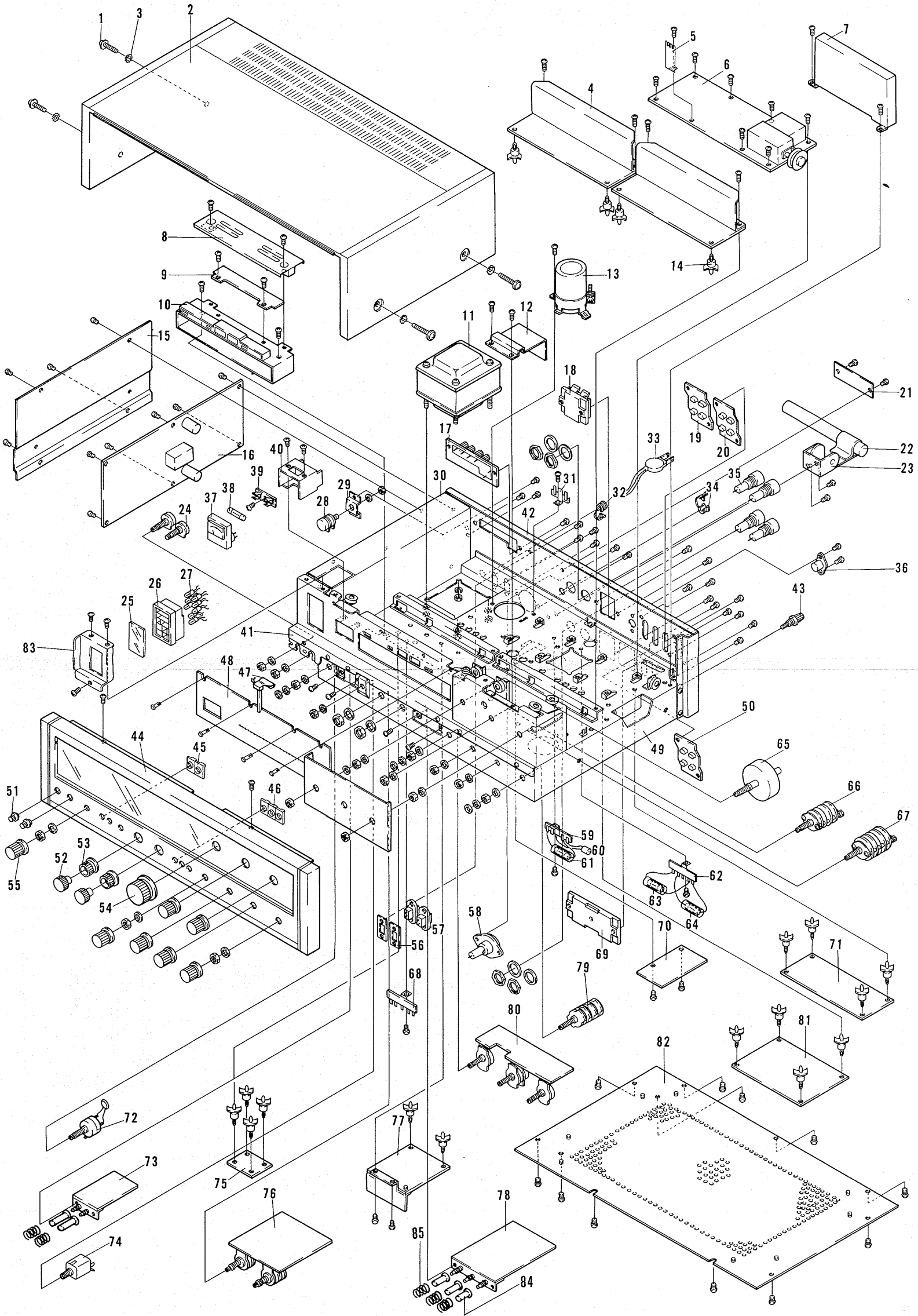



# 12. SCHEMATIC DIAGRAMS, P.C. BOARD PATTERNS AND PARTS LISTS

## 12.1 CIRCUIT CONNECTION DIAGRAM AND MISCELLANEOUS PARTS

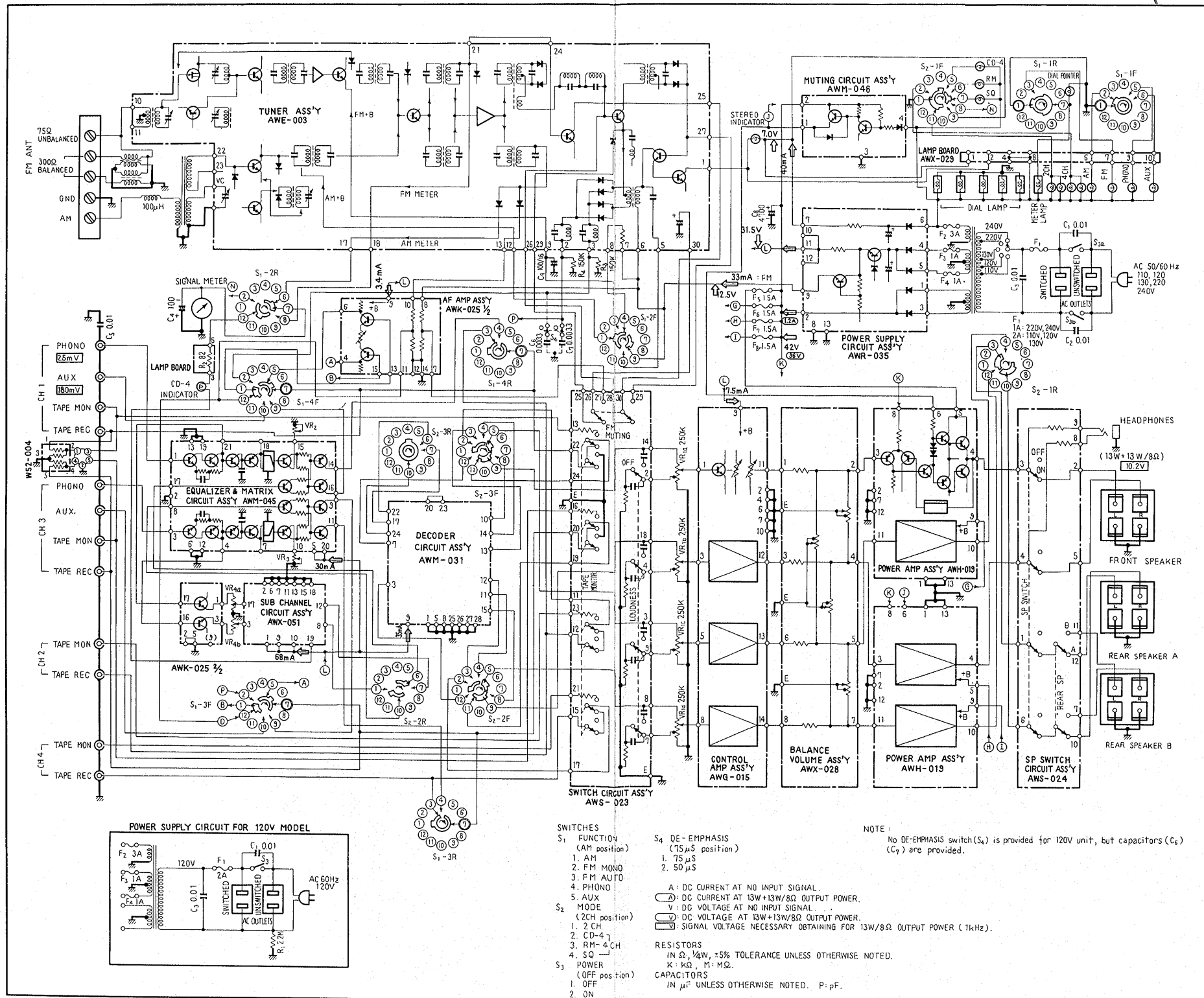

- CAPACITORS: IN  $\mu$ F UNLESS OTHERWISE NOTED p: pF
- RESISTORS: IN  $\Omega$ ,  $\frac{1}{2}$ W UNLESS OTHERWISE NOTED k: k $\Omega$ , M: M $\Omega$

**Miscellaneous Parts List**

**CAPACITORS**

Symbol	Description	Part No.	
C1	Ceramic 0.01 150V	ACG-002-0	KUW model
	Ceramic 0.01 250V	ACG-001-0	
C2	Ceramic 0.01 250V	ACG-001-0	FW model FW model only
	Metallized mylar 0.01 800V	ACE-002-0	
C3	Ceramic 0.01 250V	ACG-001-0	KUW model FW model
	Electrolytic 100 16V	CEA 101P 16	
C4	Electrolytic 100 16V	CEA 101P 16	
C5	Ceramic 0.01 50V	CKDYF 103Z 50	
C6	Mylar 0.0033 50V	CQMA 332J 50	
C7	Mylar 0.0033 50V	CQMA 332J 50	
C8	Electrolytic 4700 50V	C52-088-C	
C9	Electrolytic 100 16V	CEA 101P 16	

**RESISTORS AND POTENTIOMETERS**

Symbol	Description	Part No.	
R1	Carbon film 2.2M $\frac{1}{2}$ W	RD $\frac{1}{2}$ PS 225J	
R2	Carbon film 82	RD $\frac{1}{2}$ PS 820J	
R3	Carbon film 150k	RD $\frac{1}{2}$ PS 154J	
R4	Carbon film 150k	RD $\frac{1}{2}$ PS 154J	
VR1	Volume control 250k-B1	ACV-306-0	
VR2	L channel separation control(CD-4) 10k-C	ACV-013-0	
VR3	R channel separation control(CD-4) 10k-C	ACV-013-0	
VR4	Carrier level control 10k-B	ACT-108-0	

**SWITCHES**

Symbol	Description	Part No.	
S1	FUNCTION switch	ASC-049-B	
S2	MODE switch	ASC-050-A	
S3	POWER switch	ASA-032-0	KUW model FW model
	POWER switch	SII-016-B	
S4	De-emphasis switch	S41-022-A	FW model only

**OTHERS**

Symbol	Description	Part No.	
	Power transformer	ATT-095-B	KUW model FW model
	Power transformer	ATT-096-B	
	AM ferrite loopstick antenna	ATB-006-0	
	Choke coil	T24-030-0	
	Balune	T22-025-A	
	Tuner assembly	AWE-003-E	
	Power amplifier assembly	AWH-019-E	
	Control amplifier assembly	AWG-015-0	
	Equalizer and matrix circuit assembly	AWM-045-0	

Symbol	Description	Part No.	
	Decoder circuit assembly	AWM-031-0	
	Power supply circuit assembly	AWR-035-0	
	Switch circuit assembly	AWS-023-0	
	Speaker switch circuit assembly	AWS-024-0	
	Muting circuit assembly	AWM-046-0	
	Lamp board assembly	AWX-029-0	
	Balance volume assembly	AWX-028-0	
	AF amplifier assembly	AWK-025-0	
	Sub channel circuit assembly	AWX-051-A	
	Dial shaft assembly	M42-071-H	
	Dial pulley assembly	AXA-003-B	
	AM antenna holder assembly	AXB-001-0	
	Foot	AEC-027-B	
	Tuning meter	AAW-003-0	
	Phono jack·A (4 Jacks)	AKB-014-0	
	Phono jack·B (4 Jacks)	AKB-015-0	
	Antenna terminal board	K11-043-D	
	Speaker output terminal (Rear)	AKE-010-0	
	Speaker output terminal (Front)	AKE-016-0	
F2	Fuse 3A (Protection)	AKE-003-0	KUW model
F2	Fuse 3A (Protection)	E21-022-0	FW model
F5~F8	Fuse 1.5A (Protection)	AEK-009-0	
F1	Fuse 2A (AC power)	E21-027-0	KUW model
F1	Fuse 1A (AC power)	E21-004-0	FW model
F3, F4	Fuse 1A (Protection)	AKE-004-0	KUW model
F3, F4	Fuse 1A (Protection)	E21-020-0	FW model
	Pilot lamp (CD-4 indicator)	AEL-006-0	
	Pilot lamp (Program and mode indicators)	AEL-007-0	
	Pilot lamp(Dial scale and signal meter)	E22-032-0	
	Headphone jack	K72-026-0	
	Fuse holder	AKR-006-0	KUW model
	Fuse holder	AKR-001-0	FW model
	Fuse holder (Protection)	AKR-012-0	
	Fuse holder (1P)	K91-005-A	
	5P connector (DIN type)	K93-003-B	
	Chassis mounting AC socket	AKP-002-0	KUW model
	Chassis mounting AC socket	AKP-004-0	FW model
	AC power cord	ADG-003-0	KUW model
	AC power cord	D11-002-B	FW model
	Binding post (Ground)	AKE-012-A	
	Color plated wide shoulder screw	ABA-010-A	
	AC cord grommet	AEC-079-0	
	Insulating spacer	AEB-018-0	
	Operating instructions	ARB-081-0	
	FM T-type antenna	D52-013-0	
	Polishing cloth	E33-009-B	
	Packing case	AHD-171-0	
	Side pad (L)	AHA-035-0	
	Side pad (R)	AHA-036-0	
	Top pad	AHB-014-0	
	Accessory box	AHC-001-0	
	Test record PQX-1011		
	Compound part (for REC terminal)	W52-004-0	

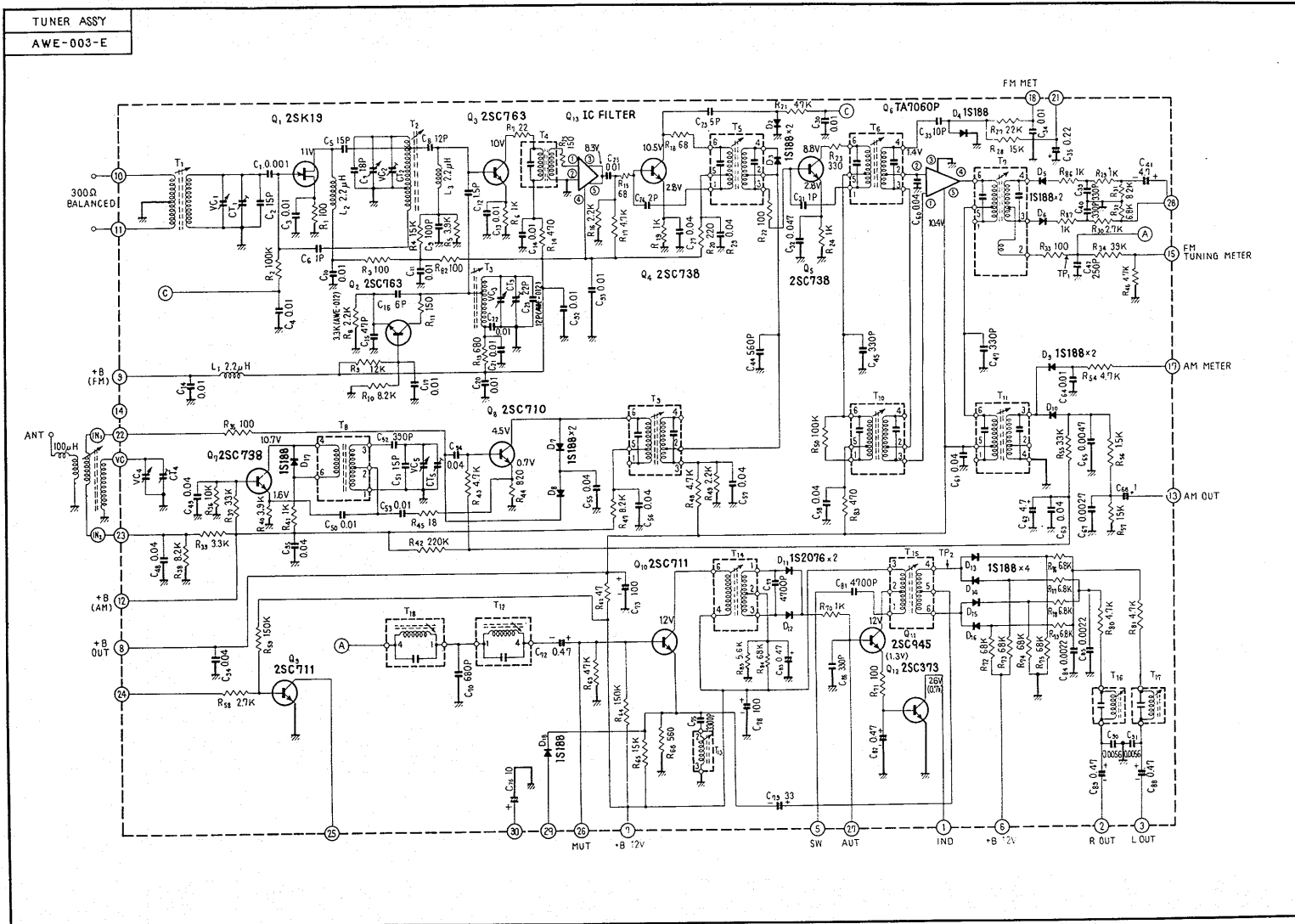

2SC373

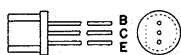

2SC945

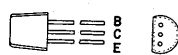

2SC711  
2SC738  
2SC763  
2SC710

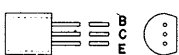

2SK19

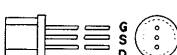

TA7060P

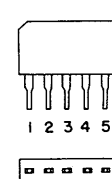

Foil side

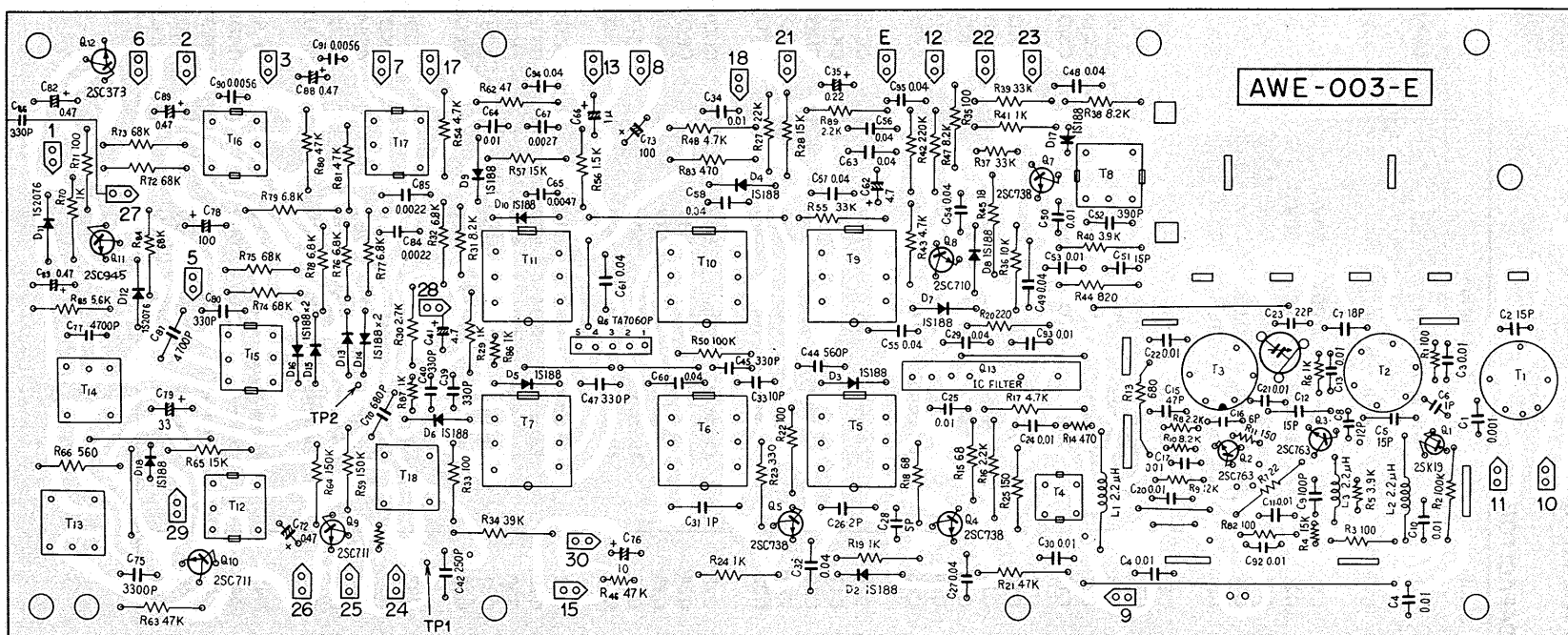

AWE-003-E

## Parts List of Tuner Assembly (AWE-003-E)

### CAPACITORS

Symbol	Description	Part No.
VC	Tuning capacitor	C64-046-0
CT3	Ceramic trimmer	C43-007-A
C1	Ceramic 0.001 50V	CKDYF 102Z 50
C2	Ceramic 15p 50V	CCDSL 150K 50
C3	Ceramic 0.01 50V	CKDYF 103Z 50
C4	Ceramic 0.01 50V	CKDYF 103Z 50
C5	Ceramic 15p 50V	CCDSL 150K 50
C6	Ceramic 1p 500V	CGB 010K 500
C7	Ceramic 18p 50V	CCDSL 180K 50
C8	Ceramic 12p 50V	CCDSL 120K 50
C9	Ceramic 100p 50V	CCDSL 101K 50
C10	Ceramic 0.01 50V	CKDYF 103Z 50
C11	Ceramic 0.01 50V	CKDYF 103Z 50
C12	Ceramic 1.5p 500V	CGB 1R5K 500
C13	Ceramic 0.01 50V	CKDYF 103Z 50
C14	Ceramic 0.01 50V	CKDYF 103Z 50
C15	Ceramic 47p 50V	CCDSL 470K 50
C16	Ceramic 6p 50V	CCDTJ 060D 50
C17	Ceramic 0.01 50V	CKDYF 103Z 50
C20	Ceramic 0.01 50V	CKDYF 103Z 50
C21	Ceramic 0.01 50V	CKDYB 103K 50
C22	Ceramic 0.01 50V	CKDYB 103K 50
C23	Ceramic 22p 50V	CCDRH 220K 50
C24	Ceramic 0.01 50V	CKDYF 103Z 50
C25	Ceramic 0.01 50V	CKDYF 103Z 50
C26	Ceramic 2p 50V	CCDSL 020C 50
C27	Ceramic 0.04 50V	CKDYF 403Z 50
C28	Ceramic 5p 50V	CCDSL 050D 50
C29	Ceramic 0.04 50V	CKDYF 403Z 50
C30	Ceramic 0.01 50V	CKDYF 103Z 50
C31	Ceramic 1p 500V	CGB 010K 500
C32	Ceramic 0.047 25V	CKDBC 473Z 25
C33	Ceramic 10p 50V	CCDSL 100F 50
C34	Ceramic 0.01 50V	CKDYF 103Z 50
C35	Electrolytic 0.22 25V	CSSA R22M 25
C39	Ceramic 330p 50V	CKDYB 331K 50
C40	Ceramic 330p 50V	CKDYB 331K 50
C41	Electrolytic 4.7 25V	CEA 4R7P 25
C42	Ceramic 250p 50V	CCDSL 251K 50
C44	Ceramic 560p 50V	CKDYB 561K 50
C45	Ceramic 330p 50V	CKDYB 331K 50
C47	Ceramic 330p 50V	CKDYB 331K 50

Symbol	Description			Part No.
C48	Ceramic	0.04	50V	CKDYF 403Z 50
C49	Ceramic	0.04	50V	CKDYF 403Z 50
C50	Mylar	0.01	50V	CQMA 103K 50
C51	Ceramic	15p	50V	CCDUJ 150K 50
C52	Styrol	390p	50V	CQSA 391K 50
C53	Mylar	0.01	50V	CQMA 103K 50
C54	Ceramic	0.04	50V	CKDYF 403Z 50
C55	Ceramic	0.04	50V	CKDYF 403Z 50
C56	Ceramic	0.04	50V	CKDYF 403Z 50
C57	Ceramic	0.04	50V	CKDYF 403Z 50
C58	Ceramic	0.04	50V	CKDYF 403Z 50
C60	Ceramic	0.04	50V	CKDYF 403Z 50
C61	Ceramic	0.04	50V	CKDYF 403Z 50
C62	Electrolytic	4.7	25V	CEA 4R7P 25
C63	Ceramic	0.04	50V	CKDYF 403Z 50
C64	Ceramic	0.01	50V	CKDYF 103Z 50
C65	Mylar	0.0047	50V	CQMA 472K 50
C66	Electrolytic	1	50V	CEA 010P 50
C67	Mylar	0.0027	50V	CQMA 272K 50
C69				
C70	Styrol	680p	50V	CQSA 681J 50
C71				
C72	Electrolytic	0.47	50V	CEA R47P 50
C73	Electrolytic	100	16V	CEA 101P 16
C75	Styrol	0.0033	50V	C15-011-A
C76	Electrolytic	10	16V	CEA 100P 16
C77	Styrol	0.0047	50V	C15-013-A
C78	Electrolytic	100	16V	CEA 101P 16
C79	Electrolytic	33	16V	CEA 330P 16
C80				
C81	Styrol	0.0047	50V	C15-013-A
C82	Electrolytic	0.47	50V	CEA R47P 50
C83	Electrolytic	0.47	50V	CEA R47P 50
C84	Mylar	0.0022	50V	CQMA 222J 50
C85	Mylar	0.0022	50V	CQMA 222J 50
C86	Ceramic	330p	50V	CKDYB 331K 50
C88	Electrolytic	0.47	50V	CEA R47P 50
C89	Electrolytic	0.47	50V	CEA R47P 50
C90	Mylar	0.0056	50V	CQMA 562K 50
C91	Mylar	0.0056	50V	CQMA 562K 50
C92	Ceramic	0.01	50V	CKDYF 103Z 50
C93	Ceramic	0.01	50V	CKDYF 103Z 50
C94	Ceramic	0.04	50V	CKDYF 403Z 50
C95	Ceramic	0.04	50V	CKDYF 403Z 50

RESISTORS

Symbol	Description	Part No.
R1	Carbon film 100	RD½VS 101J
R2	Carbon film 100k	RD½PS 104J
R3	Carbon film 100	RD½VS 101J
R4	Carbon film 15k	RD½VS 153J
R5	Carbon film 3.9k	RD½VS 392J
R6	Carbon film 1k	RD½VS 102J
R7	Carbon film 22	RD½VS 220J
R8	Carbon film 2.2k	RD½VS 222J
R9	Carbon film 12k	RD½VS 123J
R10	Carbon film 8.2k	RD½VS 822J
R11	Carbon film 150	RD½VS 151J
R13	Carbon film 680	RD½PS 681J
R14	Carbon film 470	RD½VS 471J
R15	Carbon film 68	RD½PS 680J
R16	Carbon film 2.2k	RD½VS 222J
R17	Carbon film 4.7k	RD½VS 472J
R18	Carbon film 68	RD½VS 680J
R19	Carbon film 1k	RD½PS 102J
R20	Carbon film 220	RD½PS 221J
R21	Carbon film 47k	RD½PS 473J
R22	Carbon film 100	RD½PS 101J
R23	Carbon film 330	RD½PS 331J
R24	Carbon film 1k	RD½PS 102J
R25	Carbon film 150	RD½PS 151J
R27	Carbon film 22k	RD½PS 223J
R28	Carbon film 15k	RD½PS 153J
R29	Carbon film 1k	RD½PS 102J
R30	Carbon film 2.7k	RD½PS 272J
R31	Carbon film 8.2k	RD½PS 822J
R32	Carbon film 6.8k	RD½PS 682J
R33	Carbon film 100	RD½PS 101J
R34	Carbon film 39k	RD½PS 393J
R35	Carbon film 100	RD½PS 101J
R36	Carbon film 10k	RD½PS 103J
R37	Carbon film 33k	RD½VS 333J
R38	Carbon film 8.2k	RD½PS 822J
R39	Carbon film 3.3k	RD½PS 332J
R40	Carbon film 3.9k	RD½PS 392J
R41	Carbon film 1k	RD½PS 102J
R42	Carbon film 220k	RD½PS 224J
R43	Carbon film 4.7k	RD½PS 472J
R44	Carbon film 820	RD½PS 821J
R45	Carbon film 18	RD½PS 180J
R46	Carbon film 4.7k	RD½VS 472J
R47	Carbon film 8.2k	RD½PS 822J
R48	Carbon film 4.7k	RD½PS 472J
R49	Carbon film 2.2k	RD½PS 222J
R50	Carbon film 100k	RD½PS 104J
R54	Carbon film 4.7k	RD½PS 472J
R55	Carbon film 33k	RD½PS 333J

Symbol	Description	Part No.
R56	Carbon film 1.5k	RD¼PS 152J
R57	Carbon film 15k	RD¼PS 153J
R58	Carbon film 2.7k	RD¼VS 272J
R59	Carbon film 150k	RD¼PS 154J
R62	Carbon film 47	RD¼PS 470J
R63	Carbon film 47k	RD¼PS 473J
R64	Carbon film 150k	RD¼PS 154J
R65	Carbon film 15k	RD¼PS 153J
R66	Carbon film 560	RD¼PS 561J
R67		
R70	Carbon film 1k	RD¼PS 102J
R71	Carbon film 100	RD¼PS 101J
R72	Carbon film 68k	RD¼PS 683J
R73	Carbon film 68k	RD¼PS 683J
R74	Carbon film 68k	RD¼PS 683J
R75	Carbon film 68k	RD¼PS 683J
R76	Carbon film 6.8k	RD¼PS 682J
R77	Carbon film 6.8k	RD¼PS 682J
R78	Carbon film 6.8k	RD¼PS 682J
R79	Carbon film 6.8k	RD¼PS 682J
R80	Carbon film 4.7k	RD¼PS 472J
R81	Carbon film 4.7k	RD¼PS 472J
R82	Carbon film 100	RD¼PS 101J
R83	Carbon film 470	RD¼PS 471J
R84	Carbon film 68k	RD¼PS 683J
R85	Carbon film 5.6k	RD¼VS 562J
R86	Carbon film 1k	RD¼VS 102J
R87	Carbon film 1k	RD¼VS 102J

### TRANSFORMERS AND COILS

Symbol	Description	Part No.
T1	FM Antenna Coil	ATC-002-0
T2	FM RF Coil	ATC-004-0
T3	FM OSC Coil	ATC-003-0
T4	Matching Transformer	ATE-001-A
T5	FM IF Transformer	T73-035-A
T6	FM IF Transformer	T73-036-0
T7	FM IF Transformer	T74-003-A
T8	AM OSC Coil	ATB-001-A
T9	AM IF Transformer	T71-028-0
T10	AM IF Transformer	T71-026-0
T11	AM IF Transformer	T72-022-0
T12	SCA Filter	ATM-006-0
T13	19kHz Transformer	T75-023-B
T14	19kHz Transformer	T75-024-B
T15	38kHz Transformer	T75-025-B
T16	38kHz Leak Filter	ATM-004-0
T17	38kHz Leak Filter	ATM-004-0
T18	SCA Filter	ATM-007-0



Symbol	Description	Part No.
L1	RF Choke Coil	T24-028-0
L2	RF Choke Coil	T24-028-0
L3	RF Choke Coil	T24-028-0

**SEMICONDUCTORS**

Symbol	Description	Part No.
Q1	FET 2SK19-Y	W53-046-A or ATF-007-0
Q2	Transistor 2SC763-D or C	
Q3	Transistor 2SC763-D or C	
Q4	Transistor 2SC738	
Q5	Transistor 2SC738	
Q6	IC TA7060P-BL	
Q7	Transistor 2SC738	
Q8	Transistor 2SC710-D or DR	
Q9	Transistor 2SC711-F	
Q10	Transistor 2SC711-E or F	
Q11	Transistor 2SC945-R	
Q12	Transistor 2SC373	
Q13	FM IC Filter	
D2	Diode 1S188 FM-1	
D3	Diode 1S188 FM-1	
D4	Diode 1S188 FM-1	
D5	Diode 1S188 FM-1	
D6	Diode 1S188 FM-1	
D7	Diode 1S188 FM-1	
D8	Diode 1S188 FM-1	
D9	Diode 1S188 FM-1	
D10	Diode 1S188 FM-1	
D11	Diode 1S2076	
D12	Diode 1S2076	
D13	Diode 1S188 FM-1	
D14	Diode 1S188 FM-1	
D15	Diode 1S188 FM-1	
D16	Diode 1S188 FM-1	
D17	Diode 1S188 FM-1	
D18	Diode 1S188 FM-1	

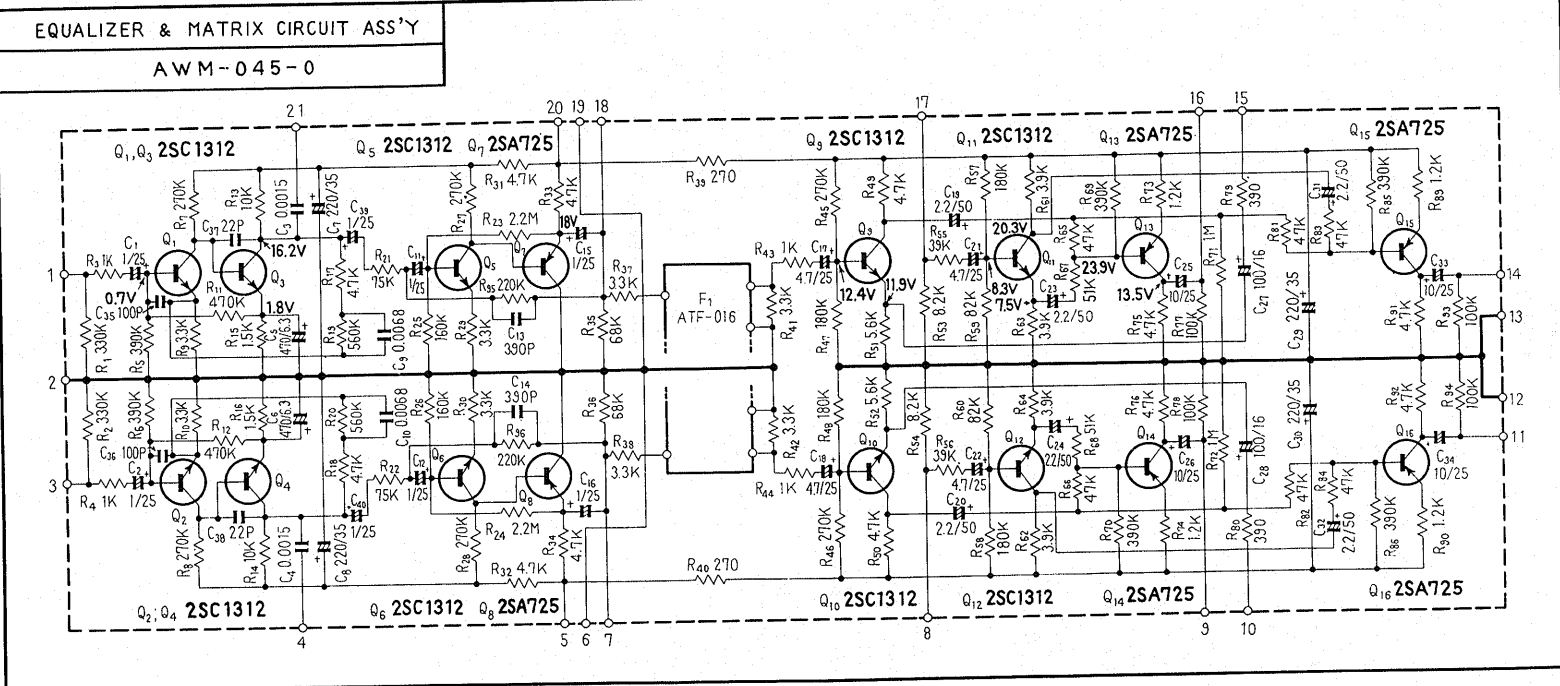

2SC1312  
2SA725

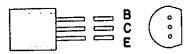

2SC1344

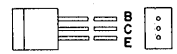

Foil side

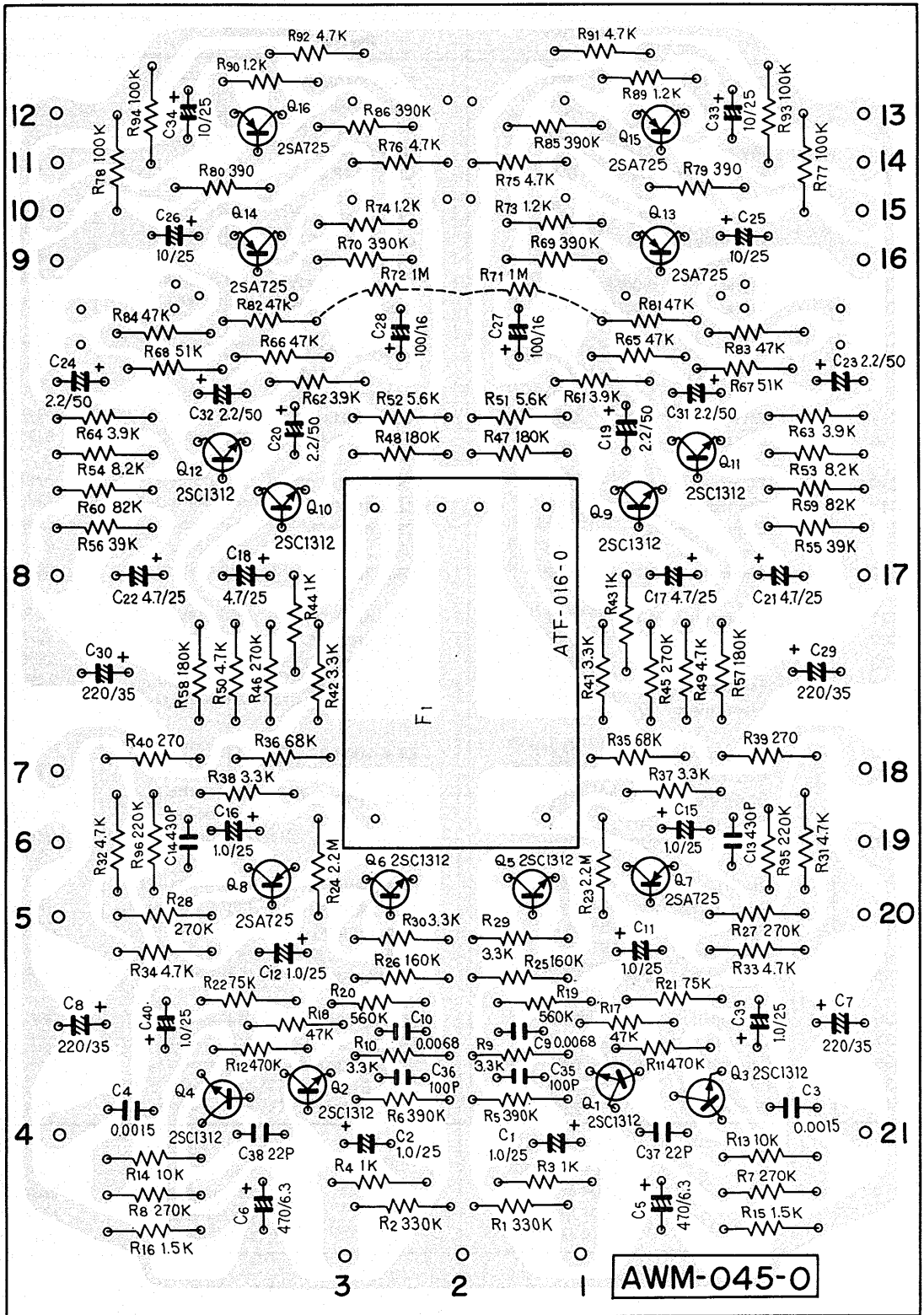

## Parts List of Equalizer and Matrix Circuit Assembly (AWM-045-0)

### CAPACITORS

Symbol	Description	Part No.
C1	Electrolytic 1 25V	CSSA 010M 25
C2	Electrolytic 1 25V	CSSA 010M 25
C3	Mylar 0.0015 50V	CQMA 152K 50
C4	Mylar 0.0015 50V	CQMA 152K 50
C5	Electrolytic 470 6V	CEA 471P 6
C6	Electrolytic 470 6V	CEA 471P 6
C7	Electrolytic 220 35V	CEA 221P 35
C8	Electrolytic 220 35V	CEA 221P 35
C9	Mylar 0.0068 50V	CQMA 682J 50
C10	Mylar 0.0068 50V	CQMA 682J 50
C11	Electrolytic 1 25V	CSSA 010M 25
C12	Electrolytic 1 25V	CSSA 010M 25
C13	Styrol 390p 50V	CQSA 391J 50
C14	Styrol 390p 50V	CQSA 391J 50
C15	Electrolytic 1 25V	CSSA 010M 25
C16	Electrolytic 1 25V	CSSA 010M 25
C17	Electrolytic 4.7 25V	CEA 4R7P 25
C18	Electrolytic 4.7 25V	CEA 4R7P 25
C19	Electrolytic 2.2 50V	CEA 2R2P 50
C20	Electrolytic 2.2 50V	CEA 2R2P 50
C21	Electrolytic 4.7 25V	CEA 4R7P 25
C22	Electrolytic 4.7 25V	CEA 4R7P 25
C23	Electrolytic 2.2 50V	CEA 2R2P 50
C24	Electrolytic 2.2 50V	CEA 2R2P 50
C25	Electrolytic 10 25V	CEA 100P 25
C26	Electrolytic 10 25V	CEA 100P 25
C27	Electrolytic 100 16V	CEA 101P 16
C28	Electrolytic 100 16V	CEA 101P 16
C29	Electrolytic 220 35V	CEA 221P 35
C30	Electrolytic 220 35V	CEA 221P 35
C31	Electrolytic 2.2 50V	CEA 2R2P 50
C32	Electrolytic 2.2 50V	CEA 2R2P 50
C33	Electrolytic 10 25V	CEA 100P 25
C34	Electrolytic 10 25V	CEA 100P 25
C35	Ceramic 100p 50V	CCDSL 101K 50
C36	Ceramic 100p 50V	CCDSL 101K 50
C37	Ceramic 22p 50V	CCDSL 220K 50
C38	Ceramic 22p 50V	CCDSL 220K 50
C39	Electrolytic 1 25V	CSSA 010M 25
C40	Electrolytic 1 25V	CSSA 010M 25

RESISTORS

Symbol	Description	Part No.
R1	Carbon film 330k	RD¼PM 334J
R2	Carbon film 330k	RD¼PM 334J
R3	Carbon film 1k	RD¼PM 102J
R4	Carbon film 1k	RD¼PM 102J
R5	Carbon film 390k	RD¼PM 394J
R6	Carbon film 390k	RD¼PM 394J
R7	Carbon film 270k	RD¼PM 274J
R8	Carbon film 270k	RD¼PM 274J
R9	Carbon film 3.3k	RD¼PM 332J
R10	Carbon film 3.3k	RD¼PM 332J
R11	Carbon film 470k	RD¼PM 474J
R12	Carbon film 470k	RD¼PM 474J
R13	Carbon film 10k	RD¼PM 103J
R14	Carbon film 10k	RD¼PM 103J
R15	Carbon film 1.5k	RD¼PM 152J
R16	Carbon film 1.5k	RD¼PM 152J
R17	Carbon film 47k	RD¼PM 473J
R18	Carbon film 47k	RD¼PM 473J
R19	Carbon film 560k	RD¼PM 564J
R20	Carbon film 560k	RD¼PM 564J
R21	Carbon film 75k	RD¼PM 753J
R22	Carbon film 75k	RD¼PM 753J
R23	Carbon film 2.2M	RD¼PM 225J
R24	Carbon film 2.2M	RD¼PM 225J
R25	Carbon film 160k	RD¼PM 164J
R26	Carbon film 160k	RD¼PM 164J
R27	Carbon film 270k	RD¼PM 274J
R28	Carbon film 270k	RD¼PM 274J
R29	Carbon film 3.3k	RD¼PM 332J
R30	Carbon film 3.3k	RD¼PM 332J
R31	Carbon film 4.7k	RD¼PM 472J
R32	Carbon film 4.7k	RD¼PM 472J
R33	Carbon film 4.7k	RD¼PM 472J
R34	Carbon film 4.7k	RD¼PM 472J
R35	Carbon film 68k	RD¼PM 683J
R36	Carbon film 68k	RD¼PM 683J
R37	Carbon film 3.3k	RD¼PM 332J
R38	Carbon film 3.3k	RD¼PM 332J
R39	Carbon film 270	RD¼PM 271J
R40	Carbon film 270	RD¼PM 271J
R41	Carbon film 3.3k	RD¼PM 332J
R42	Carbon film 3.3k	RD¼PM 332J
R43	Carbon film 1k	RD¼PM 102J
R44	Carbon film 1k	RD¼PM 102J
R45	Carbon film 270k	RD¼PM 274J

Symbol	Description	Part No.
R46	Carbon film 270k	RD¼PM 274J
R47	Carbon film 180k	RD¼PM 184J
R48	Carbon film 180k	RD¼PM 184J
R49	Carbon film 4.7k	RD¼PM 472J
R50	Carbon film 4.7k	RD¼PM 472J
R51	Carbon film 5.6k	RD¼PM 562J
R52	Carbon film 5.6k	RD¼PM 562J
R53	Carbon film 8.2k	RD¼PM 822J
R54	Carbon film 8.2k	RD¼PM 822J
R55	Carbon film 39k	RD¼PM 393J
R56	Carbon film 39k	RD¼PM 393J
R57	Carbon film 180k	RD¼PM 184J
R58	Carbon film 180k	RD¼PM 184J
R59	Carbon film 82k	RD¼PM 823J
R60	Carbon film 82k	RD¼PM 823J
R61	Carbon film 3.9k	RD¼PM 392J
R62	Carbon film 3.9k	RD¼PM 392J
R63	Carbon film 3.9k	RD¼PM 392J
R64	Carbon film 3.9k	RD¼PM 392J
R65	Carbon film 47k	RD¼PM 473J
R66	Carbon film 47k	RD¼PM 473J
R67	Carbon film 51k	RD¼PM 513J
R68	Carbon film 51k	RD¼PM 513J
R69	Carbon film 390k	RD¼PM 394J
R70	Carbon film 390k	RD¼PM 394J
R71	Carbon film 1M	RD¼PM 105J
R72	Carbon film 1M	RD¼PM 105J
R73	Carbon film 1.2k	RD¼PM 122J
R74	Carbon film 1.2k	RD¼PM 122J
R75	Carbon film 4.7k	RD¼PM 472J
R76	Carbon film 4.7k	RD¼PM 472J
R77	Carbon film 100k	RD¼PM 104J
R78	Carbon film 100k	RD¼PM 104J
R79	Carbon film 390	RD¼PM 391J
R80	Carbon film 390	RD¼PM 391J
R81	Carbon film 47k	RD¼PM 473J
R82	Carbon film 47k	RD¼PM 473J
R83	Carbon film 47k	RD¼PM 473J
R84	Carbon film 47k	RD¼PM 473J
R85	Carbon film 390k	RD¼PM 394J
R86	Carbon film 390k	RD¼PM 394J
R87	Carbon film 220k	RD¼PM 224J
R88	Carbon film 220k	RD¼PM 224J
R89	Carbon film 1.2k	RD¼PM 122J
R90	Carbon film 1.2k	RD¼PM 122J
R91	Carbon film 4.7k	RD¼PM 472J
R92	Carbon film 4.7k	RD¼PM 472J
R93	Carbon film 100k	RD¼PM 104J
R94	Carbon film 100k	RD¼PM 104J
R95	Carbon film 220k	RD¼PM 224J
R96	Carbon film 220k	RD¼PM 224J

**SEMICONDUCTORS**

Symbol	Description	Part No.
Q1	Transistor 2SC1312-G or H (2SC1344-E or F)	
Q2	Transistor 2SC1312-G or H (2SC1344-E or F)	
Q3	Transistor 2SC1312-G or H (2SC1344-E or F)	
Q4	Transistor 2SC1312-G or H (2SC1344-E or F)	
Q5	Transistor 2SC1312-G or H (2SC1344-E or F)	
Q6	Transistor 2SC1312-G or H (2SC1344-E or F)	
Q7	Transistor 2SA725-G or F	
Q8	Transistor 2SA725-G or F	
Q9	Transistor 2SC1312-G or H (2SC1344-E or F)	
Q10	Transistor 2SC1312-G or H (2SC1344-E or F)	
Q11	Transistor 2SC1312-G or H (2SC1344-E or F)	
Q12	Transistor 2SC1312-G or H (2SC1344-E or F)	
Q13	Transistor 2SA725-G or F	
Q14	Transistor 2SA725-G or F	
Q15	Transistor 2SA725-G or F	
Q16	Transistor 2SA725-G or F	

**FILTER**

Symbol	Description	Part No.
F1	Low pass filter	ATF-016-0

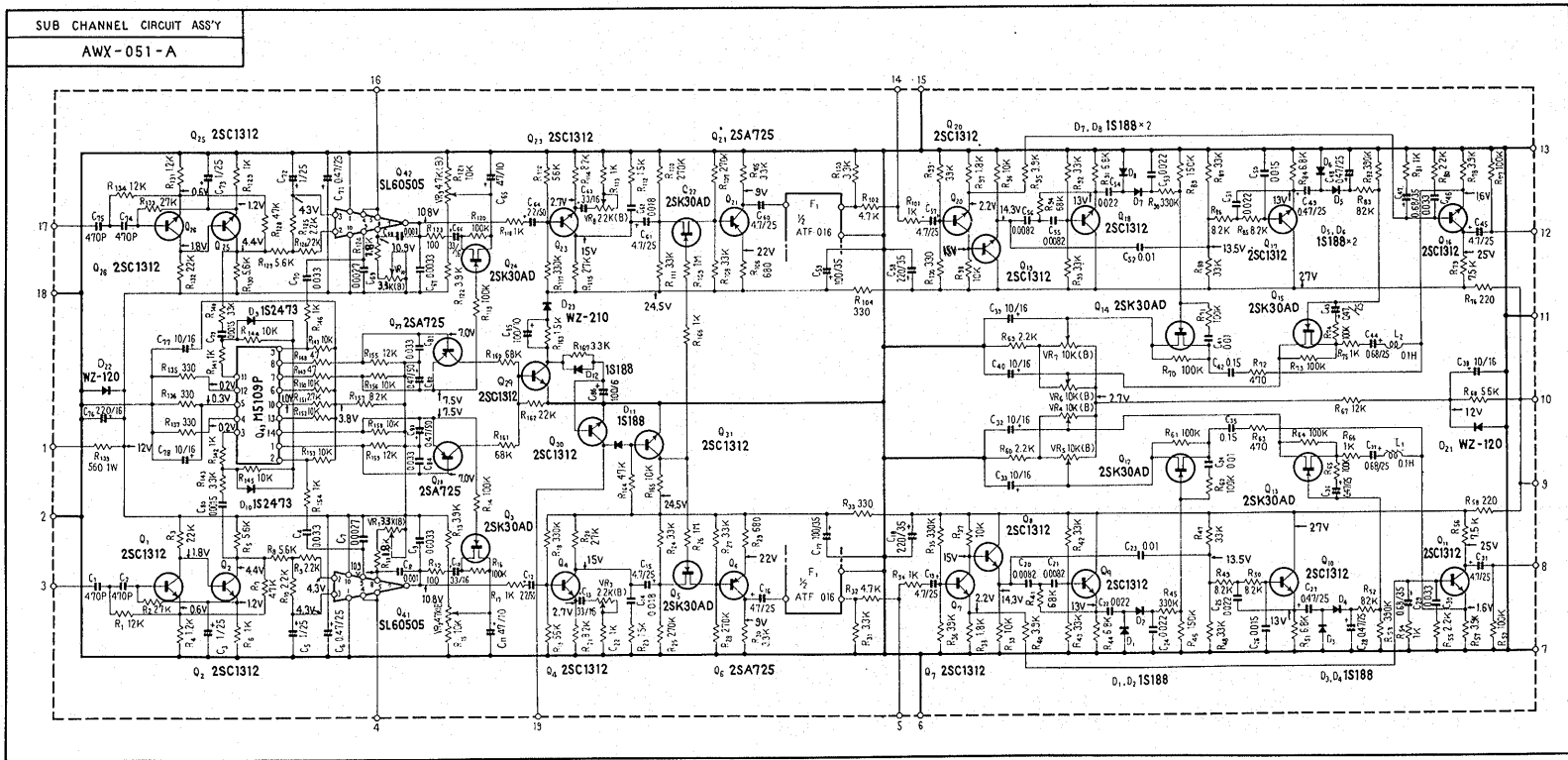

2SC1312  
2SA725

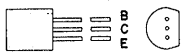

2SC1344



2SK30AD

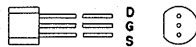

SL60505  
LM565CN  
CD894N  
LM565CH  
M5109P

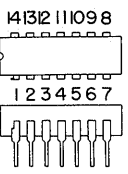



Foil side

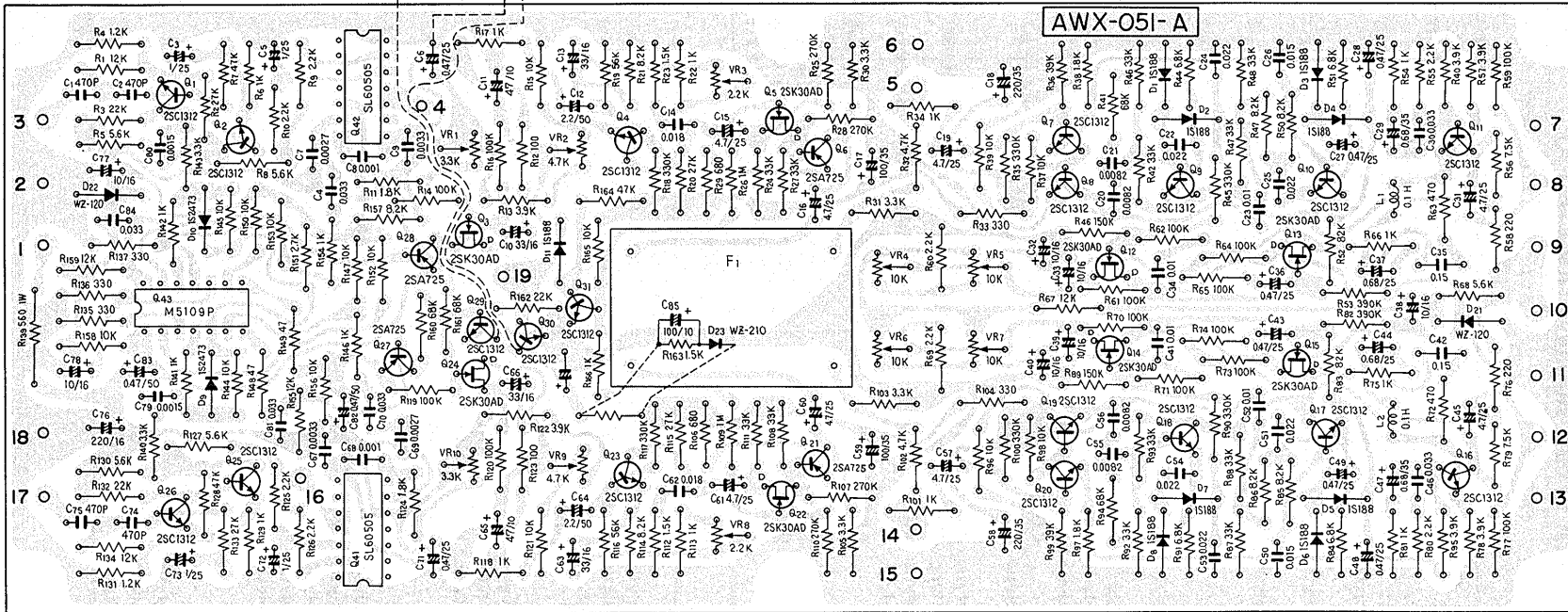

## Parts List of Sub Channel Circuit Assembly (AWX-051-A)

### CAPACITORS

Symbol	Description	Part No.
C1	Ceramic 470p 50V	CKDYB 471K 50
C2	Ceramic 470p 50V	CKDYB 471K 50
C3	Electrolytic 1 25V	CEA 010P 25
C4	Mylar 0.033 50V	CQMA 333K 50
C5	Electrolytic 1 25V	CEA 010P 25
C6	Electrolytic 0.47 25V	CSSA R47M 25
C7	Mylar 0.0027 50V	CQMA 272K 50
C8	Mylar 0.001 50V	CQMA 102K 50
C9	Mylar 0.0033 50V	CQMA 332K 50
C10	Electrolytic 33 16V	CEA 330P 16
C11	Electrolytic 220 10V	CEA 221P 10
C12	Electrolytic 2.2 50V	CEA 2R2P 50
C13	Electrolytic 33 16V	CEA 330P 16
C14	Mylar 0.018 50V	CQMA 183K 50
C15	Electrolytic 4.7 25V	CEA 4R7P 25
C16	Electrolytic 4.7 25V	CEA 4R7P 25
C17	Electrolytic 100 35V	CEA 101P 35
C18	Electrolytic 220 35V	CEA 221P 35
C19	Electrolytic 4.7 25V	CEA 4R7P 25
C20	Mylar 0.0082 50V	CQMA 822K 50
C21	Mylar 0.0082 50V	CQMA 822K 50
C22	Mylar 0.022 50V	CQMA 223K 50
C23	Mylar 0.01 50V	CQMA 103K 50
C24	Mylar 0.022 50V	CQMA 223K 50
C25	Mylar 0.022 50V	CQMA 223K 50
C26	Mylar 0.015 50V	CQMA 153K 50
C27	Electrolytic 0.47 25V	CSSA R47M 25
C28	Electrolytic 0.47 25V	CSSA R47M 25
C29	Electrolytic 0.68 35V	CSZA R68K 35
C30	Mylar 0.033 50V	CQMA 333K 50
C31	Electrolytic 4.7 25V	CEA 4R7P 25
C32	Electrolytic 10 16V	CEA 100P 16
C33	Electrolytic 10 16V	CEA 100P 16
C34	Mylar 0.01 50V	CQMA 103K 50
C35	Mylar 0.15 50V	CQMA 154K 50
C36	Electrolytic 0.47 25V	CSSA R47M 25
C37	Electrolytic 0.68 25V	CSSA R68M 25
C38	Electrolytic 10 16V	CEA 100P 16
C39	Electrolytic 10 16V	CEA 100P 16
C40	Electrolytic 10 16V	CEA 100P 16
C41	Mylar 0.01 50V	CQMA 103K 50
C42	Mylar 0.15 50V	CQMA 154K 50
C43	Electrolytic 0.47 25V	CSSA R47M 25
C44	Electrolytic 0.68 25V	CSSA R68M 25
C45	Electrolytic 4.7 25V	CEA 4R7P 25

Symbol	Description	Part No.
C46	Mylar 0.033 50V	CQMA 333K 50
C47	Electrolytic 0.68 35V	CSZA R68K 35
C48	Electrolytic 0.47 25V	CSSA R47M 25
C49	Electrolytic 0.47 25V	CSSA R47M 25
C50	Mylar 0.015 50V	CQMA 153K 50
C51	Mylar 0.022 50V	CQMA 223K 50
C52	Mylar 0.01 50V	CQMA 103K 50
C53	Mylar 0.022 50V	CQMA 223K 50
C54	Mylar 0.022 50V	CQMA 223K 50
C55	Mylar 0.0082 50V	CQMA 822K 50
C56	Mylar 0.0082 50V	CQMA 822K 50
C57	Electrolytic 4.7 25V	CEA 4R7P 25
C58	Electrolytic 220 35V	CEA 221P 35
C59	Electrolytic 100 35V	CEA 101P 35
C60	Electrolytic 4.7 25V	CEA 4R7P 25
C61	Electrolytic 4.7 25V	CEA 4R7P 25
C62	Mylar 0.018 50V	CQMA 183K 50
C63	Electrolytic 33 16V	CEA 330P 16
C64	Electrolytic 2.2 50V	CEA 2R2P 50
C65	Electrolytic 220 10V	CEA 221P 10
C66	Electrolytic 33 16V	CEA 330P 16
C67	Mylar 0.0033 50V	CQMA 332K 50
C68	Mylar 0.001 50V	CQMA 102K 50
C69	Mylar 0.0027 50V	CQMA 272K 50
C70	Mylar 0.033 50V	CQMA 333K 50
C71	Electrolytic 0.47 25V	CSSA R47M 25
C72	Electrolytic 1 25V	CEA 010P 25
C73	Electrolytic 1 25V	CEA 010P 25
C74	Ceramic 470p 50V	CKDYB 471K 50
C75	Ceramic 470p 50V	CKDYB 471K 50
C76	Electrolytic 220 16V	CEA 221P 16
C77	Electrolytic 10 16V	CEA 100P 16
C78	Electrolytic 10 16V	CEA 100P 16
C79	Mylar 0.0015 50V	CQMA 152K 50
C80	Mylar 0.0015 50V	CQMA 152K 50
C81	Mylar 0.033 50V	CQMA 333K 50
C82	Electrolytic 0.47 50V	CEA R47P 50
C83	Electrolytic 0.47 50V	CEA R47P 50
C84	Mylar 0.033 50V	CQMA 333K 50
C85	Electrolytic 100 10V	CEA 101P 10
C86	Electrolytic 100 6V	CEA 101P 6

## RESISTORS

Symbol	Description	Part No.
R1	Carbon film 12k	RD¼PM 123J
R2	Carbon film 27k	RD¼PM 273J
R3	Carbon film 22k	RD¼PM 223J
R4	Carbon film 1.2k	RD¼PM 122J
R5	Carbon film 5.6k	RD¼PM 562J
R6	Carbon film 1k	RD¼PM 102J
R7	Carbon film 47k	RD¼PM 473J
R8	Carbon film 5.6k	RD¼PM 562J
R9	Carbon film 2.2k	RD¼PM 222J
R10	Carbon film 2.2k	RD¼PM 222J
R11	Carbon film 1.8k	RD¼PM 182J
R12	Carbon film 100	RD¼PM 101J
R13	Carbon film 3.9k	RD¼PM 392J
R14	Carbon film 100k	RD¼PM 104J
R15	Carbon film 10k	RD¼PM 103J
R16	Carbon film 100k	RD¼PM 104J
R17	Carbon film 1k	RD¼PM 102J
R18	Carbon film 330k	RD¼PM 334J
R19	Carbon film 56k	RD¼PM 563J
R20	Carbon film 27k	RD¼PM 273J
R21	Carbon film 8.2k	RD¼PM 822J
R22	Carbon film 1k	RD¼PM 102J
R23	Carbon film 1.5k	RD¼PM 152J
R24	Carbon film 33k	RD¼PM 333J
R25	Carbon film 270k	RD¼PM 274J
R26	Carbon film 1M	RD¼PM 105J
R27	Carbon film 33k	RD¼PM 333J
R28	Carbon film 270k	RD¼PM 274J
R29	Carbon film 680	RD¼PM 681J
R30	Carbon film 3.3k	RD¼PM 332J
R31	Carbon film 3.3k	RD¼PM 332J
R32	Carbon film 4.7k	RD¼PM 472J
R33	Carbon film 330	RD¼PM 331J
R34	Carbon film 1k	RD¼PM 102J
R35	Carbon film 330k	RD¼PM 334J
R36	Carbon film 39k	RD¼PM 393J
R37	Carbon film 10k	RD¼PM 103J
R38	Carbon film 1.8k	RD¼PM 182J
R39	Carbon film 10k	RD¼PM 103J
R40	Carbon film 3.9k	RD¼PM 392J
R41	Carbon film 68k	RD¼PM 683J
R42	Carbon film 33k	RD¼PM 333J
R43	Carbon film 33k	RD¼PM 333J
R44	Carbon film 6.8k	RD¼PM 682J
R45	Carbon film 330k	RD¼PM 334J
R46	Carbon film 150k	RD¼PM 154J
R47	Carbon film 33k	RD¼PM 333J
R48	Carbon film 33k	RD¼PM 333J
R49	Carbon film 8.2k	RD¼PM 822J
R50	Carbon film 8.2k	RD¼PM 822J

Symbol	Description	Part No.
R51	Carbon film 6.8k	RD¼PM 682J
R52	Carbon film 82k	RD¼PM 823J
R53	Carbon film 390k	RD¼PM 394J
R54	Carbon film 1k	RD¼PM 102J
R55	Carbon film 2.2k	RD¼PM 222J
R56	Carbon film 7.5k	RD¼PM 752J
R57	Carbon film 3.9k	RD¼PM 392J
R58	Carbon film 220	RD¼PM 221J
R59	Carbon film 100k	RD¼PM 104J
R60	Carbon film 2.2k	RD¼PM 222J
R61	Carbon film 100k	RD¼PM 104J
R62	Carbon film 100k	RD¼PM 104J
R63	Carbon film 470	RD¼PM 471J
R64	Carbon film 100k	RD¼PM 104J
R65	Carbon film 100k	RD¼PM 104J
R66	Carbon film 1k	RD¼PM 102J
R67	Carbon film 12k	RD¼PM 123J
R68	Carbon film 5.6k	RD¼PM 562J
R69	Carbon film 2.2k	RD¼PM 222J
R70	Carbon film 100k	RD¼PM 104J
R71	Carbon film 100k	RD¼PM 104J
R72	Carbon film 470	RD¼PM 471J
R73	Carbon film 100k	RD¼PM 104J
R74	Carbon film 100k	RD¼PM 104J
R75	Carbon film 1k	RD¼PM 102J
R76	Carbon film 220	RD¼PM 221J
R77	Carbon film 100k	RD¼PM 104J
R78	Carbon film 3.9k	RD¼PM 392J
R79	Carbon film 7.5k	RD¼PM 752J
R80	Carbon film 2.2k	RD¼PM 222J
R81	Carbon film 1k	RD¼PM 102J
R82	Carbon film 390k	RD¼PM 394J
R83	Carbon film 82k	RD¼PM 823J
R84	Carbon film 6.8k	RD¼PM 682J
R85	Carbon film 8.2k	RD¼PM 822J
R86	Carbon film 8.2k	RD¼PM 822J
R87	Carbon film 33k	RD¼PM 333J
R88	Carbon film 33k	RD¼PM 333J
R89	Carbon film 150k	RD¼PM 154J
R90	Carbon film 330k	RD¼PM 334J
R91	Carbon film 6.8k	RD¼PM 682J
R92	Carbon film 33k	RD¼PM 333J
R93	Carbon film 33k	RD¼PM 333J
R94	Carbon film 68k	RD¼PM 683J
R95	Carbon film 3.9k	RD¼PM 392J
R96	Carbon film 10k	RD¼PM 103J
R97	Carbon film 1.8k	RD¼PM 182J
R98	Carbonfilm 10k	RD¼PM 103J
R99	Carbon film 39k	RD¼PM 393J
R100	Carbon film 330k	RD¼PM 334J

Symbol	Description	Part No.
R101	Carbon film 1k	RD¼PM 102J
R102	Carbon film 4.7k	RD¼PM 472J
R103	Carbon film 3.3k	RD¼PM 332J
R104	Carbon film 330	RD¼PM 331J
R105	Carbon film 3.3k	RD¼PM 332J
R106	Carbon film 680	RD¼PM 681J
R107	Carbon film 270k	RD¼PM 274J
R108	Carbon film 33k	RD¼PM 333J
R109	Carbon film 1M	RD¼PM 105J
R110	Carbon film 270k	RD¼PM 274J
R111	Carbon film 33k	RD¼PM 333J
R112	Carbon film 1.5k	RD¼PM 152J
R113	Carbon film 1k	RD¼PM 102J
R114	Carbon film 8.2k	RD¼PM 822J
R115	Carbon film 27k	RD¼PM 273J
R116	Carbon film 56k	RD¼PM 563J
R117	Carbon film 330k	RD¼PM 334J
R118	Carbon film 1k	RD¼PM 102J
R119	Carbon film 100k	RD¼PM 104J
R120	Carbon film 100k	RD¼PM 104J
R121	Carbon film 10k	RD¼PM 103J
R122	Carbon film 3.9k	RD¼PM 392J
R123	Carbon film 100	RD¼PM 101J
R124	Carbon film 1.8k	RD¼PM 182J
R125	Carbon film 2.2k	RD¼PM 222J
R126	Carbon film 2.2k	RD¼PM 222J
R127	Carbon film 5.6k	RD¼PM 562J
R128	Carbon film 47k	RD¼PM 473J
R129	Carbon film 1k	RD¼PM 102J
R130	Carbon film 5.6k	RD¼PM 562J
R131	Carbon film 1.2k	RD¼PM 122J
R132	Carbon film 22k	RD¼PM 223J
R133	Carbon film 27k	RD¼PM 273J
R134	Carbon film 12k	RD¼PM 123J
R135	Carbon film 330	RD¼PM 331J
R136	Carbon film 330	RD¼PM 331J
R137	Carbon film 330	RD¼PM 331J
R138		
R139	Metal oxide 560 1W	RS1P 561J
R140	Carbon film 3.3k	RD¼PM 332J
R141	Carbon film 1k	RD¼PM 102J
R142	Carbon film 1k	RD¼PM 102J
R143	Carbon film 3.3k	RD¼PM 332J
R144	Carbon film 10k	RD¼PM 103J
R145	Carbon film 10k	RD¼PM 103J
R146	Carbon film 1k	RD¼PM 102J
R147	Carbon film 10k	RD¼PM 103J
R148	Carbon film 47	RD¼PM 470J
R149	Carbon film 47	RD¼PM 470J
R150	Carbon film 10k	RD¼PM 103J

Symbol	Description	Part No.
R151	Carbon film 2.7k	RD¼PM 272J
R152	Carbon film 10k	RD¼PM 103J
R153	Carbon film 10k	RD¼PM 103J
R154	Carbon film 1k	RD¼PM 102J
R155	Carbon film 12k	RD¼PM 123J
R156	Carbon film 10k	RD¼PM 103J
R157	Carbon film 8.2k	RD¼PM 822J
R158	Carbon film 10k	RD¼PM 103J
R159	Carbon film 12k	RD¼PM 123J
R160	Carbon film 68k	RD¼PM 683J
R161	Carbon film 68k	RD¼PM 683J
R162	Carbon film 22k	RD¼PM 223J
R163	Carbon film 1.5k	RD¼PM 152J
R164	Carbon film 47k	RD¼PM 473J
R165	Carbon film 10k	RD¼PM 103J
R166	Carbon film 1k	RD¼PM 102J
R167	Carbon film 3.3k	RD¼PM 332J

POTENTIOMETERS

Symbol	Description	Part No.
VR1	Semi-fixed 3.3k-B	ACP-028-0
VR2	Semi-fixed 4.7k-B	C92-051-0
VR3	Semi-fixed 2.2k-B	ACP-001-0
VR4	Semi-fixed 10k-B	C92-049-0
VR5	Semi-fixed 10k-B	C92-049-0
VR6	Semi-fixed 10k-B	C92-049-0
VR7	Semi-fixed 10k-B	C92-049-0
VR8	Semi-fixed 2.2k-B	ACP-001-0
VR9	Semi-fixed 4.7k-B	C92-051-0
VR10	Semi-fixed 3.3k-B	ACP-028-0

SEMICONDUCTORS

Symbol	Description	Part No.
Q1	Transistor 2SC1312-F or G (2SC1344-D or E)	
Q2	Transistor 2SC1312-F or G (2SC1344-D or E)	
Q3	FET 2SK30AD	
Q4	Transistor 2SC1312-F or G (2SC1344-D or E)	
Q5	FET 2SK30AD	
Q6	Transistor 2SA725-F or G	
Q7	Transistor 2SC1312-F or G (2SC1344-D or E)	
Q8	Transistor 2SC1312-F or G (2SC1344-D or E)	
Q9	Transistor 2SC1312-F or G (2SC1344-D or E)	
Q10	Transistor 2SC1312-F or G (2SC1344-D or E)	

Symbol	Description	Part No.
Q11	Transistor 2SC1312-F or G (2SC1344-D or E)	
Q12	FET 2SK30AD	
Q13	FET 2SK30AD	
Q14	FET 2SK30AD	
Q15	FET 2SK30AD	
Q16	Transistor 2SC1312-F or G (2SC1344-D or E)	
Q17	Trnasistor 2SC1312-F or G (2SC1344-D or E)	
Q18	Transistor 2SC1312-F or G (2SC1344-D or E)	
Q19	Transistor 2SC1312-F or G (2SC1344-D or E)	
Q20	Transistor 2SC1312-F or G (2SC1344-D or E)	
Q21	Transistor 2SA725-F or G	
Q22	FET 2SK30AD	
Q23	Transistor 2SC1312-F or G (2SC1344-D or E)	
Q24	FET 2SK30AD	
Q25	Transistor 2SC1312-F or G (2SC1344-D or E)	
Q26	Transistor 2SC1312-F or G (2SC1344-D or E)	
Q27	Transistor 2SA725-F or G	
Q28	Transistor 2SA725-F or G	
Q29	Transistor 2SC1312-F or G (2SC1344-D or E)	
Q30	Transistor 2SC1312-H (2SC1344-F)	
Q31	Transistor 2SC1312-F or G (2SC1344-D or E)	
Q41	IC SL60505 (LM565CN) (LM565CH)	
Q42	IC SL60505 (LM565CN) (LM565CH) (CD894N)	
Q43	IC M5109P	
D1	Diode 1S188FM	
D2	Diode 1S188FM	
D3	Diode 1S188FM	
D4	Diode 1S188FM	
D5	Diode 1S188FM	



Symbol	Description	Part No.
D6	Diode 1S188FM	
D7	Diode 1S188FM	
D8	Diode 1S188FM	
D9	Diode 1S2473	
D10	Diode 1S2473	
D11	Diode 1S188FM	
D12	Diode 1S188FM	
D21	Zener Diode WZ-120	
D22	Zener Diode WZ-120	
D23	Zener Diode WZ-210	

**COILS AND FILTER**

Symbol	Description	Part No.
F1	Low pass filter	ATF-016-0
L1	Choke coil 104k	ATM-008-0
L2	Choke coil 104k	ATM-008-0



2SC1312  
2SA725

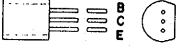

Foil side

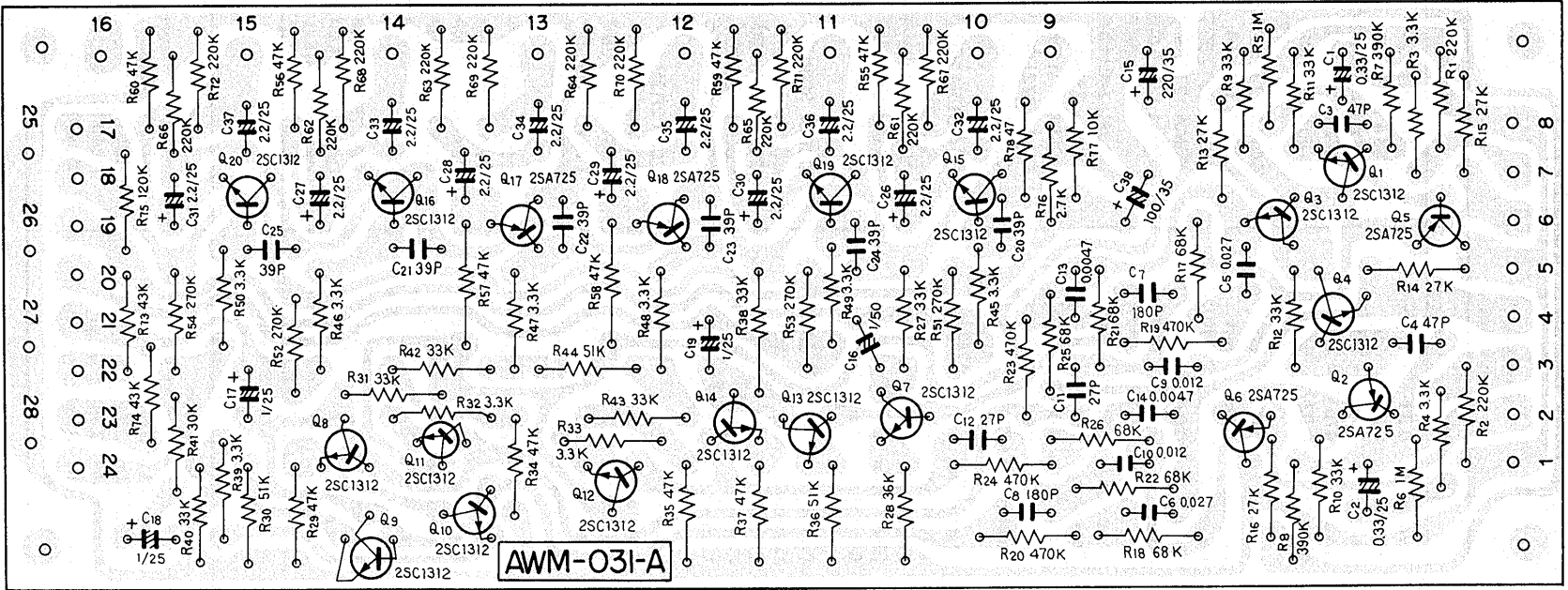

## Parts List of Decoder Circuit Assembly (AWM-031-A)

### CAPACITORS

Symbol	Description	Part No.
C1	Electrolytic 0.33 25V	CSSA R33M 25
C2	Electrolytic 0.33 25V	CSSA R33M 25
C3	Ceramic 47p 50V	CCDSL 470K 50
C4	Ceramic 47p 50V	CCDSL 470K 50
C5	Mylar 0.027 50V	CQMA 273J 50
C6	Mylar 0.027 50V	CQMA 273J 50
C7	Ceramic 180p 50V	CCDSL 181J 50
C8	Ceramic 180p 50V	CCDSL 181J 50
C9	Mylar 0.012 50V	CQMA 123J 50
C10	Mylar 0.012 50V	CQMA 123J 50
C11	Ceramic 27p 50V	CCDSL 270J 50
C12	Ceramic 27p 50V	CCDSL 270J 50
C13	Mylar 0.0047 50V	CQMA 472J 50
C14	Mylar 0.0047 50V	CQMA 472J 50
C15	Electrolytic 220 35V	CEA 221P 35
C16	Electrolytic 1 25V	CEA 010M 25NP
C17	Electrolytic 1 25V	CSSA 010M 25
C18	Electrolytic 1 25V	CSSA 010M 25
C19	Electrolytic 1 25V	CSSA 010M 25
C20	Ceramic 39p 50V	CCDSL 390K 50
C21	Ceramic 39p 50V	CCDSL 390K 50
C22	Ceramic 39p 50V	CCDSL 390K 50
C23	Ceramic 39p 50V	CCDSL 390K 50
C24	Ceramic 39p 50V	CCDSL 390K 50
C25	Ceramic 39p 50V	CCDSL 390K 50
C26	Electrolytic 2.2 25V	CSSA 2R2M 25
C27	Electrolytic 2.2 25V	CSSA 2R2M 25
C28	Electrolytic 2.2 25V	CSSA 2R2M 25
C29	Electrolytic 2.2 25V	CSSA 2R2M 25
C30	Electrolytic 2.2 25V	CSSA 2R2M 25
C31	Electrolytic 2.2 25V	CSSA 2R2M 25
C32	Electrolytic 2.2 25V	CEA 2R2M 25NP
C33	Electrolytic 2.2 25V	CEA 2R2M 25NP
C34	Electrolytic 2.2 25V	CEA 2R2M 25NP
C35	Electrolytic 2.2 25V	CEA 2R2M 25NP
C36	Electrolytic 2.2 25V	CEA 2R2M 25NP
C37	Electrolytic 2.2 25V	CEA 2R2M 25NP
C38	Electrolytic 100 35V	CEA 101P 35

### RESISTORS

Symbol	Description	Part No.
R1	Carbon film 220k	RD¼PM 224J
R2	Carbon film 220k	RD¼PM 224J
R3	Carbon film 3.3k	RD¼PM 332J
R4	Carbon film 3.3k	RD¼PM 332J
R5	Carbon film 1M	RD¼PM 105J

Symbol	Description	Part No.
R6	Carbon film 1M	RD¼PM 105J
R7	Carbon film 390k	RD¼PM 394J
R8	Carbon film 390k	RD¼PM 394J
R9	Carbon film 33k	RD¼PM 333J
R10	Carbon film 33k	RD¼PM 333J
R11	Carbon film 33k	RD¼PM 333J
R12	Carbon film 33k	RD¼PM 333J
R13	Carbon film 27k	RD¼PM 273J
R14	Carbon film 27k	RD¼PM 273J
R15	Carbon film 27k	RD¼PM 273J
R16	Carbon film 27k	RD¼PM 273J
R17	Carbon film 68k	RD¼PM 683J
R18	Carbon film 68k	RD¼PM 683J
R19	Carbon film 470k	RD¼PM 474J
R20	Carbon film 470k	RD¼PM 474J
R21	Carbon film 68k	RD¼PM 683J
R22	Carbon film 68k	RD¼PM 683J
R23	Carbon film 470k	RD¼PM 474J
R24	Carbon film 470k	RD¼PM 474J
R25	Carbon film 68k	RD¼PM 683J
R26	Carbon film 68k	RD¼PM 683J
R27	Carbon film 33k	RD¼PM 333J
R28	Carbon film 36k	RD¼PM 363J
R29	Carbon film 47k	RD¼PM 473J
R30	Carbon film 51k	RD¼PM 513J
R31	Carbon film 33k	RD¼PM 333J
R32	Carbon film 3.3k	RD¼PM 332J
R33	Carbon film 3.3k	RD¼PM 332J
R34	Carbon film 47k	RD¼PM 473J
R35	Carbon film 47k	RD¼PM 473J
R36	Carbon film 51k	RD¼PM 513J
R37	Carbon film 47k	RD¼PM 473J
R38	Carbon film 33k	RD¼PM 333J
R39	Carbon film 3.3k	RD¼PM 332J
R40	Carbon film 33k	RD¼PM 333J
R41	Carbon film 30k	RD¼PM 303J
R42	Carbon film 33k	RD¼PM 333J
R43	Carbon film 33k	RD¼PM 333J
R44	Carbon film 51k	RD¼PM 513J
R45	Carbon film 3.3k	RD¼PM 332J
R46	Carbon film 3.3k	RD¼PM 332J
R47	Carbon film 3.3k	RD¼PM 332J
R48	Carbon film 3.3k	RD¼PM 332J
R49	Carbon film 3.3k	RD¼PM 332J
R50	Carbon film 3.3k	RD¼PM 332J
R51	Carbon film 270k	RD¼PM 274J
R52	Carbon film 270k	RD¼PM 274J
R53	Carbon film 270k	RD¼PM 274J
R54	Carbon film 270k	RD¼PM 274J
R55	Carbon film 47k	RD¼PM 473J

Symbol	Description	Part No.
R56	Carbon film 47k	RD¼PM 473J
R57	Carbon film 47k	RD¼PM 473J
R58	Carbon film 47k	RD¼PM 473J
R59	Carbon film 47k	RD¼PM 473J
R60	Carbon film 47k	RD¼PM 473J
R61	Carbon film 220k	RD¼PM 224J
R62	Carbon film 220k	RD¼PM 224J
R63	Carbon film 220k	RD¼PM 224J
R64	Carbon film 220k	RD¼PM 224J
R65	Carbon film 220k	RD¼PM 224J
R66	Carbon film 220k	RD¼PM 224J
R67	Carbon film 220k	RD¼PM 224J
R68	Carbon film 220k	RD¼PM 224J
R69	Carbon film 220k	RD¼PM 224J
R70	Carbon film 220k	RD¼PM 224J
R71	Carbon film 220k	RD¼PM 224J
R72	Carbon film 220k	RD¼PM 224J
R73	Carbon film 43k	RD¼PM 433J
R74	Carbon film 43k	RD¼PM 433J
R75	Carbon film 120k	RD¼PM 124J
R76	Carbon film 2.7k	RD¼PM 272J
R77	Carbon film 10k	RD¼PM 103J
R78	Carbon film 47	RD¼PM 470J

## SEMICONDUCTORS

Symbol	Description	Part No.
Q1	Transistor 2SC1312-F or G	
Q2	Transistor 2SA725-F or G	
Q3	Transistor 2SC1312-F or G	
Q4	Transistor 2SC1312-F or G	
Q5	Transistor 2SA725-F or G	
Q6	Transistor 2SA725-F or G	
Q7	Transistor 2SC1312-G	
Q8	Transistor 2SC1312-G	
Q9	Transistor 2SC1312-G	
Q10	Transistor 2SC1312-G	
Q11	Transistor 2SC1312-G	
Q12	Transistor 2SC1312-G	
Q13	Transistor 2SC1312-G	
Q14	Transistor 2SC1312-G	
Q15	Transistor 2SC1312-F or G	
Q16	Transistor 2SC1312-F or G	
Q17	Transistor 2SA725-F or G	
Q18	Transistor 2SA725-F or G	
Q19	Transistor 2SC1312-F or G	
Q20	Transistor 2SC1312-F or G	

12.6 CONTROL AMPLIFIER ASSEMBLY (AWG-015-0)

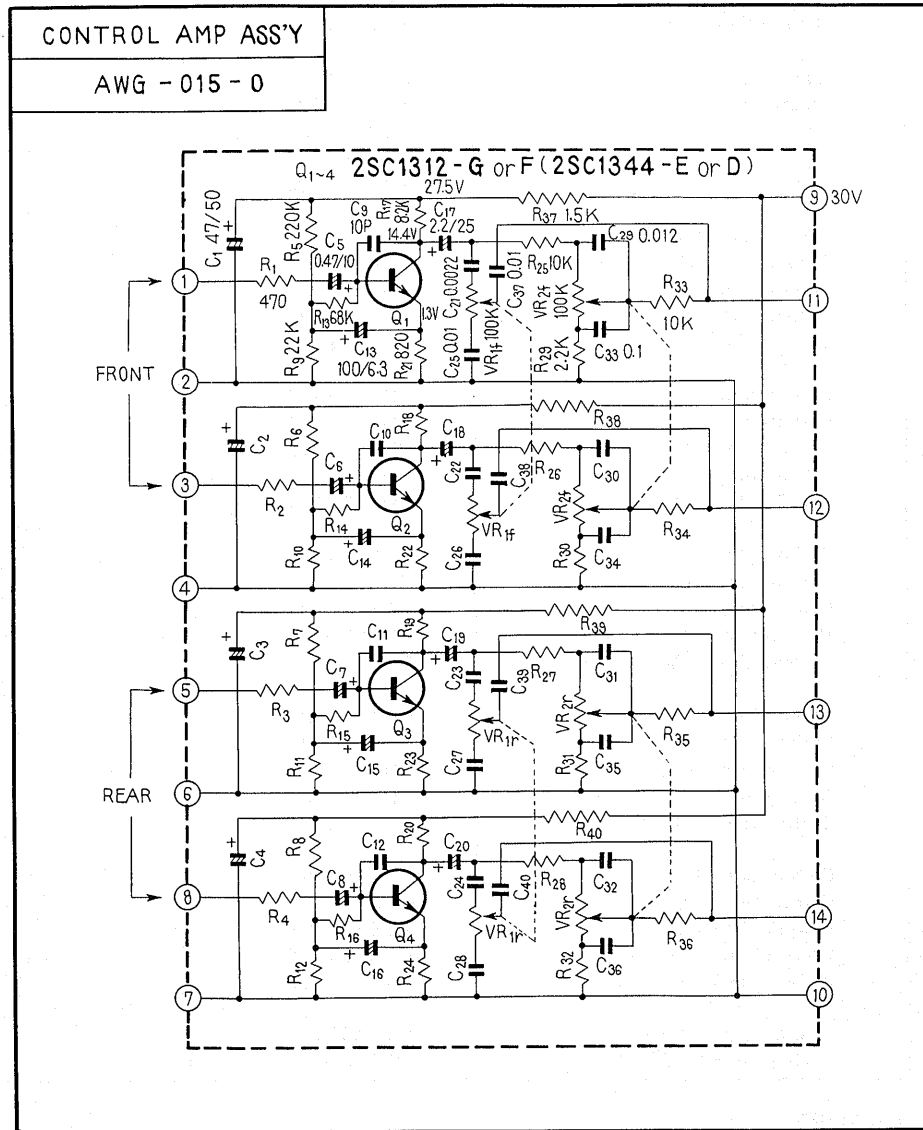

Foil Side

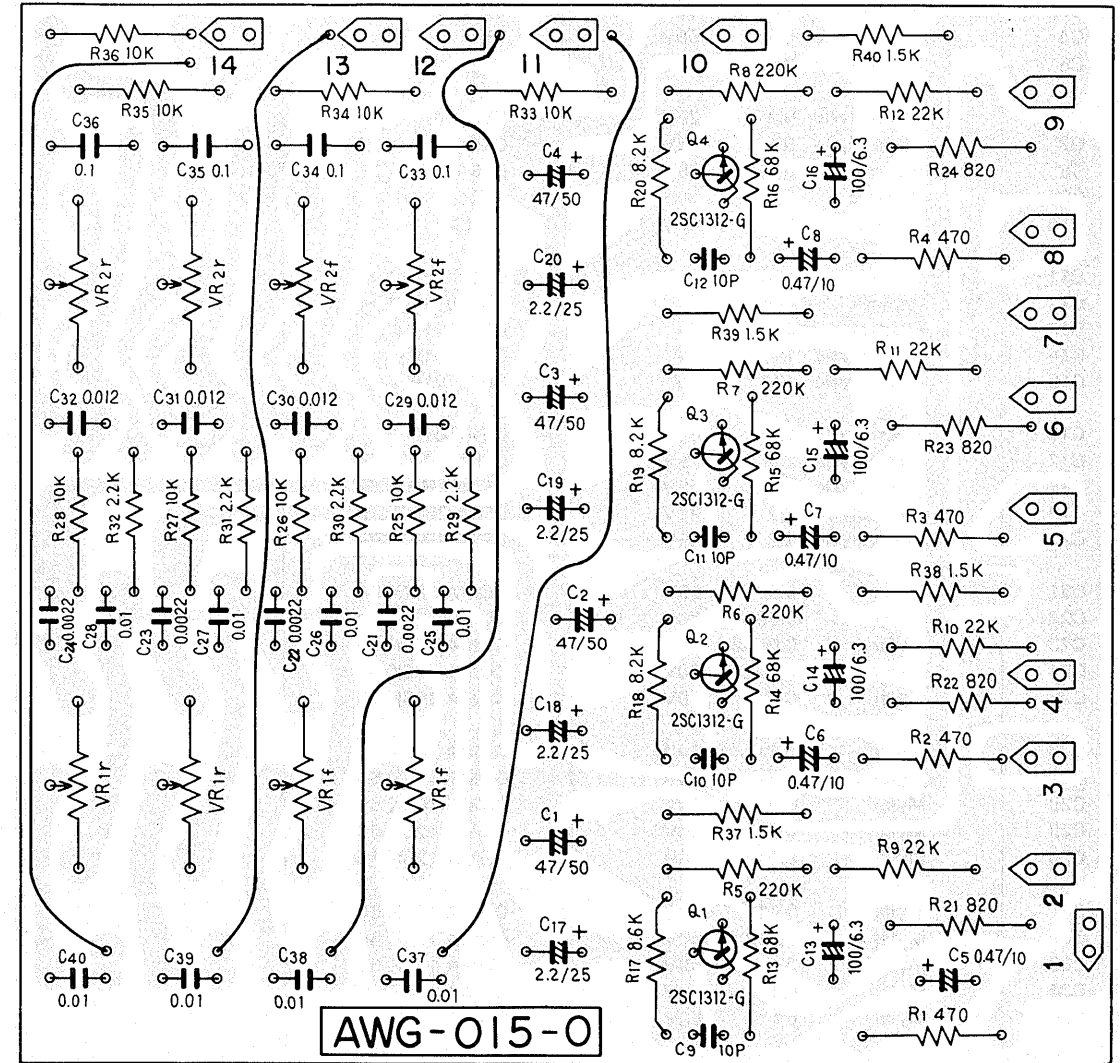

2SC1312

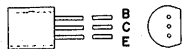

2SC1344

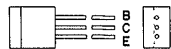

## Parts List of Control Amplifier Assembly (AWG-015-0)

### CAPACITORS

Symbol	Description	Part No.
C1	Electrolytic 47 50V	CEA 470P 50
C2	Electrolytic 47 50V	CEA 470P 50
C3	Electrolytic 47 50V	CEA 470P 50
C4	Electrolytic 47 50V	CEA 470P 50
C5	Electrolytic 0.47 25V	CSSA R47M 25
C6	Electrolytic 0.47 25V	CSSA R47M 25
C7	Electrolytic 0.47 25V	CSSA R47M 25
C8	Electrolytic 0.47 25V	CSSA R47M 25
C9	Ceramic 10p 50V	CCDSL 100F 50
C10	Ceramic 10p 50V	CCDSL 100F 50
C11	Ceramic 10p 50V	CCDSL 100F 50
C12	Ceramic 10p 50V	CCDSL 100F 50
C13	Electrolytic 100 6V	CEA 101P 6
C14	Electrolytic 100 6V	CEA 101P 6
C15	Electrolytic 100 6V	CEA 101P 6
C16	Electrolytic 100 6V	CEA 101P 6
C17	Electrolytic 2.2 25V	CSSA 2R2X 25
C18	Electrolytic 2.2 25V	CSSA 2R2X 25
C19	Electrolytic 2.2 25V	CSSA 2R2X 25
C20	Electrolytic 2.2 25V	CSSA 2R2X 25
C21	Mylar 0.0022 50V	CQMA 222K 50
C22	Mylar 0.0022 50V	CQMA 222K 50
C23	Mylar 0.0022 50V	CQMA 222K 50
C24	Mylar 0.0022 50V	CQMA 222K 50
C25	Mylar 0.01 50V	CQMA 103K 50
C26	Mylar 0.01 50V	CQMA 103K 50
C27	Mylar 0.01 50V	CQMA 103K 50
C28	Mylar 0.01 50V	CQMA 103K 50
C29	Mylar 0.012 50V	CQMA 123K 50
C30	Mylar 0.012 50V	CQMA 123K 50
C31	Mylar 0.012 50V	CQMA 123K 50
C32	Mylar 0.012 50V	CQMA 123K 50
C33	Mylar 0.1 50V	CQMA 104K 50
C34	Mylar 0.1 50V	CQMA 104K 50
C35	Mylar 0.1 50V	CQMA 104K 50
C36	Mylar 0.1 50V	CQMA 104K 50
C37	Mylar 0.01 50V	CQMA 103K 50
C38	Mylar 0.01 50V	CQMA 103K 50
C39	Mylar 0.01 50V	CQMA 103K 50
C40	Mylar 0.01 50V	CQMA 103K 50

### RESISTORS AND POTENTIOMETERS

Symbol	Description	Part No.
R1	Carbon film 470	RD½PS 471J
R2	Carbon film 470	RD½PS 471J
R3	Carbon film 470	RD½PS 471J
R4	Carbon film 470	RD½PS 471J
R5	Carbon film 220k	RD½PS 224J



Symbol	Description	Part No.
R6	Carbon film 220k	RD¼PS 224J
R7	Carbon film 220k	RD¼PS 224J
R8	Carbon film 220k	RD¼PS 224J
R9	Carbon film 22k	RD¼PS 223J
R10	Carbon film 22k	RD¼PS 223J
R11	Carbon film 22k	RD¼PS 223J
R12	Carbon film 22k	RD¼PS 223J
R13	Carbon film 68k	RD¼PS 683J
R14	Carbon film 68k	RD¼PS 683J
R15	Carbon film 68k	RD¼PS 683J
R16	Carbon film 68k	RD¼PS 683J
R17	Carbon film 8.2k	RD¼PS 822J
R18	Carbon film 8.2k	RD¼PS 822J
R19	Carbon film 8.2k	RD¼PS 822J
R20	Carbon film 8.2k	RD¼PS 822J
R21	Carbon film 820	RD¼PS 821J
R22	Carbon film 820	RD¼PS 821J
R23	Carbon film 820	RD¼PS 821J
R24	Carbon film 820	RD¼PS 821J
R25	Carbon film 10k	RD¼PS 103J
R26	Carbon film 10k	RD¼PS 103J
R27	Carbon film 10k	RD¼PS 103J
R28	Carbon film 10k	RD¼PS 103J
R29	Carbon film 2.2k	RD¼PS 222J
R30	Carbon film 2.2k	RD¼PS 222J
R31	Carbon film 2.2k	RD¼PS 222J
R32	Carbon film 2.2k	RD¼PS 222J
R33	Carbon film 10k	RD¼PS 103J
R34	Carbon film 10k	RD¼PS 103J
R35	Carbon film 10k	RD¼PS 103J
R36	Carbon film 10k	RD¼PS 103J
R37	Carbon film 1.5k	RD¼PS 152J
R38	Carbon film 1.5k	RD¼PS 152J
R39	Carbon film 1.5k	RD¼PS 152J
R40	Carbon film 1.5k	RD¼PS 152J
VR1	Bass control, 100k-B	ACV-401-0
VR2	Treble control, 100k-B	ACV-401-0

## SEMICONDUCTORS

Symbol	Description	Part No.
Q1	Transistor 2SC1312-G or F (2SC1344-E or D)	
Q2	Transistor 2SC1312-G or F (2SC1344-E or D)	
Q3	Transistor 2SC1312-G or F (2SC1344-E or D)	
Q4	Transistor 2SC1312-G or F (2SC1344-E or D)	

12.7 MUTING ASSEMBLY (AWM-046-0)

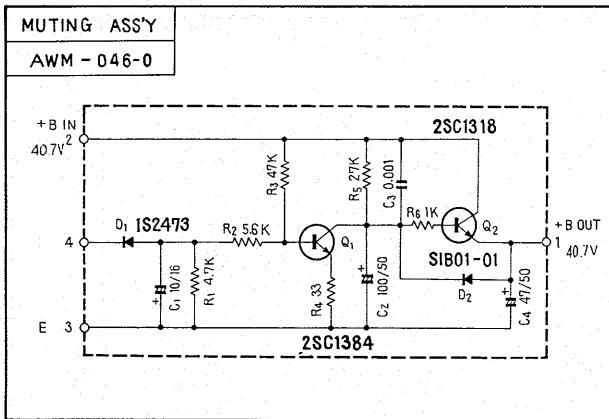

2SC1318

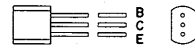

2SC1384

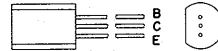

Foil side

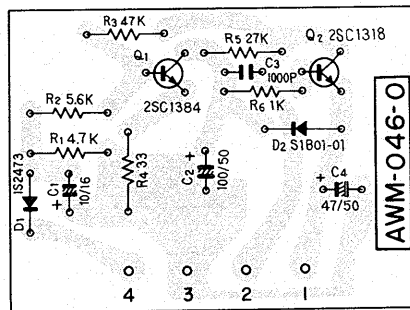

CAPACITORS

Symbol	Description	Part No.
C1	Electrolytic 10 16V	CEA 100P 16
C2	Electrolytic 100 50V	CEA 101P 50
C3	Ceramic 0.001 50V	CKDYF 102Z 50
C4	Electrolytic 47 50	CEA 470P 50

RESISTORS

Symbol	Description	Part No.
R1	Carbon film 4.7k	RD¼PM 472J
R2	Carbon film 5.6k	RD¼PM 562J
R3	Carbon film 47k	RD¼PM 473J
R4	Carbon film 33	RD¼PM 330J
R5	Carbon film 27k	RD¼PM 273J
R6	Carbon film 1k	RD¼PM 102J

SEMICONDUCTORS

Symbol	Description	Part No.
Q1	Transistor 2SC1384-R or Q	
Q2	Transistor 2SC1318-R or Q	
D1	Diode 1S2473	
D2	Diode SIB01-01	

2SC789

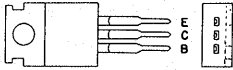

2SA720  
2SC1318

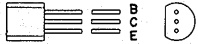

2SA725

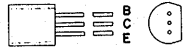

POWER AMP ASS'Y

AWH-019-F

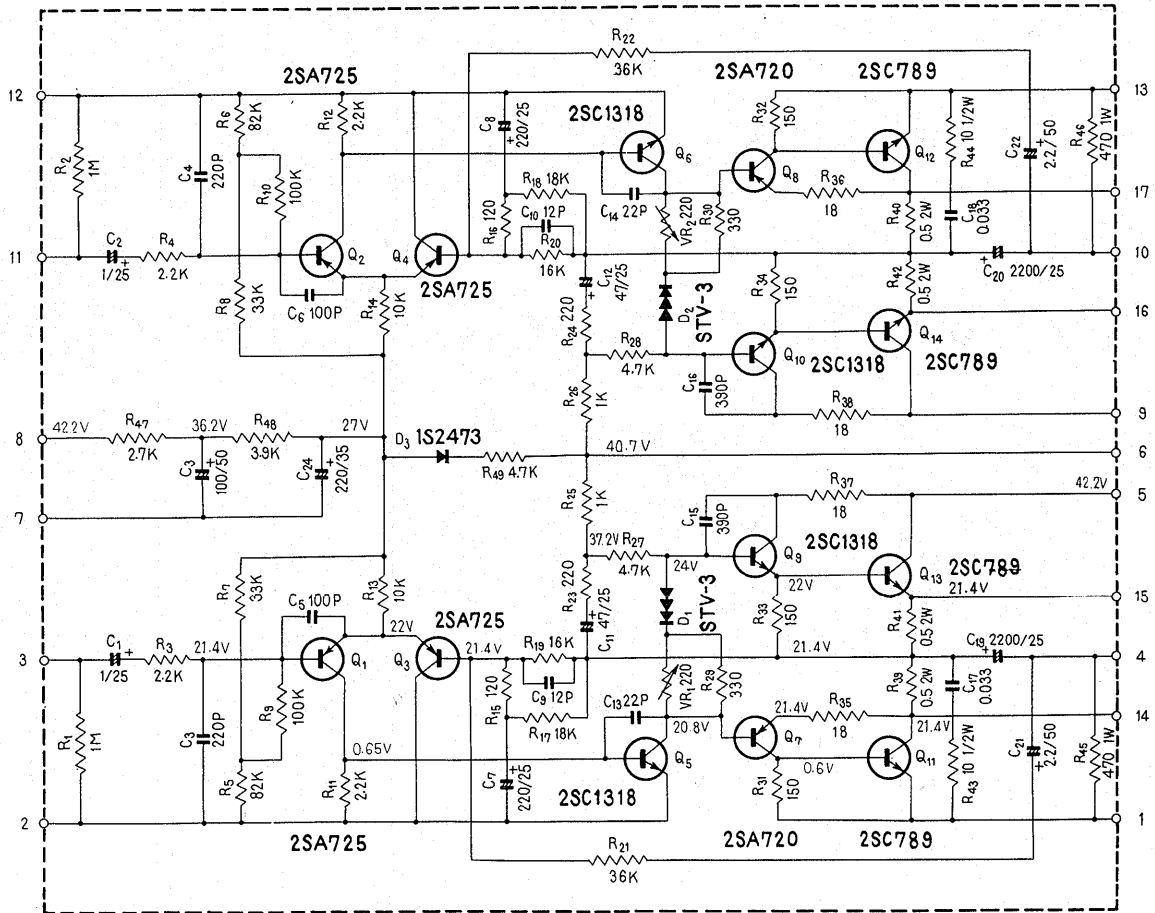

Foil side

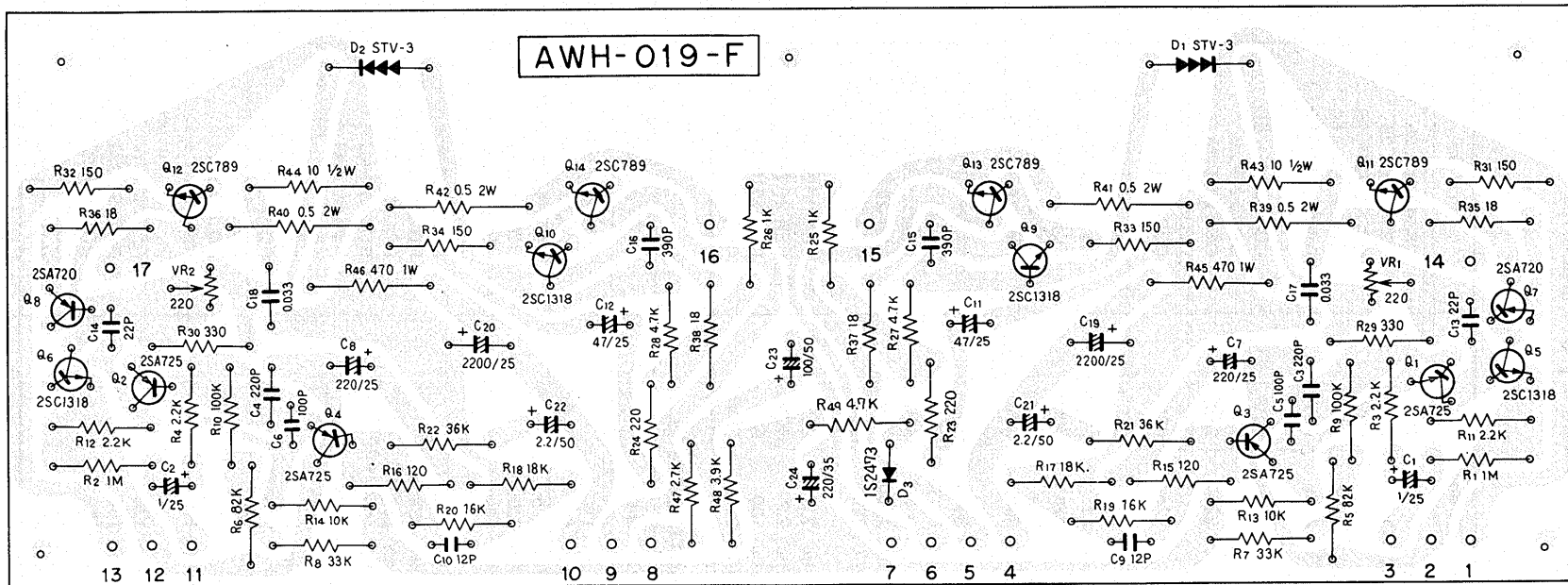

## Parts List of Power Amplifier Assembly (AWH-019-F)

### CAPACITORS

Symbol	Description	Part No.
C1	Electrolytic 1 25V	CSSA 010X 25
C2	Electrolytic 1 25V	CSSA 010X 25
C3	Ceramic 220p 50V	CCDSL 221K 50
C4	Ceramic 220p 50V	CCDSL 221K 50
C5	Ceramic 100p 50V	CCDSL 101K 50
C6	Ceramic 100p 50V	CCDSL 101K 50
C7	Electrolytic 220 25V	CEA 221P 25
C8	Electrolytic 220 25V	CEA 221P 25
C9	Ceramic 12p 50V	CCDSL 120K 50
C10	Ceramic 12p 50V	CCDSL 120K 50
C11	Electrolytic 47 25V	CEA 470P 25
C12	Electrolytic 47 25V	CEA 470P 25
C13	Ceramic 22p 50V	CCDSL 220K 50
C14	Ceramic 22p 50V	CCDSL 220K 50
C15	Ceramic 390p 50V	CKDYB 391K 50
C16	Ceramic 390p 50V	CKDYB 391K 50
C17	Mylar 0.033 50V	CQMA 333K 50
C18	Mylar 0.033 50V	CQMA 333K 50
C19	Electrolytic 2200 25V	CEA 222P 25
C20	Electrolytic 2200 25V	CEA 222P 25
C21	Electrolytic 2.2 50V	CEA 2R2P 50
C22	Electrolytic 2.2 50V	CEA 2R2P 50
C23	Electrolytic 100 50V	CEA 101P 50
C24	Electrolytic 220 35V	CEA 221P 35

### RESISTORS AND POTENTIOMETERS

Symbol	Description	Part No.
R1	Carbon film 1M	RD¼PS 105J
R2	Carbon film 1M	RD¼PS 105J
R3	Carbon film 2.2k	RD¼PS 222J
R4	Carbon film 2.2k	RD¼PS 222J
R5	Carbon film 82k	RD¼PS 823J
R6	Carbon film 82k	RD¼PS 823J
R7	Carbon film 33k	RD¼PS 333J
R8	Carbon film 33k	RD¼PS 333J
R9	Carbon film 100k	RD¼PS 104J
R10	Carbon film 100k	RD¼PS 104J
R11	Carbon film 2.2k	RD¼PS 222J
R12	Carbon film 2.2k	RD¼PS 222J
R13	Carbon film 10k	RD¼PS 103J
R14	Carbon film 10k	RD¼PS 103J
R15	Carbon film 120	RD¼PS 121J
R16	Carbon film 120	RD¼PS 121J
R17	Carbon film 18k	RD¼PS 183J
R18	Carbon film 18k	RD¼PS 183J
R19	Carbon film 16k	RD¼PS 163J
R20	Carbon film 16k	RD¼PS 163J

Symbol	Description	Part No.
R21	Carbon film 36k	RD½PS 363J
R22	Carbon film 36k	RD½PS 363J
R23	Carbon film 220	RD½PS 221J
R24	Carbon film 220	RD½PS 221J
R25	Carbon film 1k	RD½PS 102J
R26	Carbon film 1k	RD½PS 102J
R27	Carbon film 4.7k	RD½PS 472J
R28	Carbon film 4.7k	RD½PS 472J
R29	Carbon film 330	RD½PS 331J
R30	Carbon film 330	RD½PS 331J
R31	Carbon film 150	RD½PS 151J
R32	Carbon film 150	RD½PS 151J
R33	Carbon film 150	RD½PS 151J
R34	Carbon film 150	RD½PS 151J
R35	Carbon film 18	RD½PS 180J
R36	Carbon film 18	RD½PS 180J
R37	Carbon film 18	RD½PS 180J
R38	Carbon film 18	RD½PS 180J
R39	Metal film 0.5 2W	RN2H 0R5K
R40	Metal film 0.5 2W	RN2H 0R5K
R41	Metal film 0.5 2W	RN2H 0R5K
R42	Metal film 0.5 2W	RN2H 0R5K
R43	Carbon film 10 ½W	RD½PS 100J
R44	Carbon film 10 ½W	RD½PS 100J
R45	Metal oxide 470 1W	RS1P 471K
R46	Metal oxide 470 1W	RS1P 471K
R47	Carbon film 2.7k	RD½PS 272J
R48	Carbon film 3.9k	RD½PS 392J
R49	Carbon film 4.7k	RD½PS 472J
VR1	Semi-fixed 220-B	C92-060-0
VR2	Semi-fixed 220-B	C92-060-0

SEMICONDUCTORS

Symbol	Description	Part No.
Q1 X	Transistor 2SA725-F or G	
Q2 X	Transistor 2SA725-F or G	
Q3 X	Transistor 2SA725-F or G	
Q4 X	Transistor 2SC725-F or G	
Q5	Transistor 2SC1318-R or Q	
Q6	Transistor 2SC1318-R or Q	
Q7	Transistor 2SA720-R or Q	
Q8	Transistor 2SA720-R or Q	
Q9 X	Transistor 2SC1318-R or Q	
Q10 X	Transistor 2SC1318-R or Q	
Q11 Y	Transistor 2SC789-R or O	
Q12 Y	Transistor 2SC789-R or O	
Q13 Y	Transistor 2SC789-R or O	
Q14 X	Transistor 2SC789-R or O	
D1	Varistor STV-3-G 220-B	
D2	Varistor STV-3-G 220-B	
D3	Diode 1S2473	

## 2.9 AF AMPLIFIER ASSEMBLY (AWK-025-0)

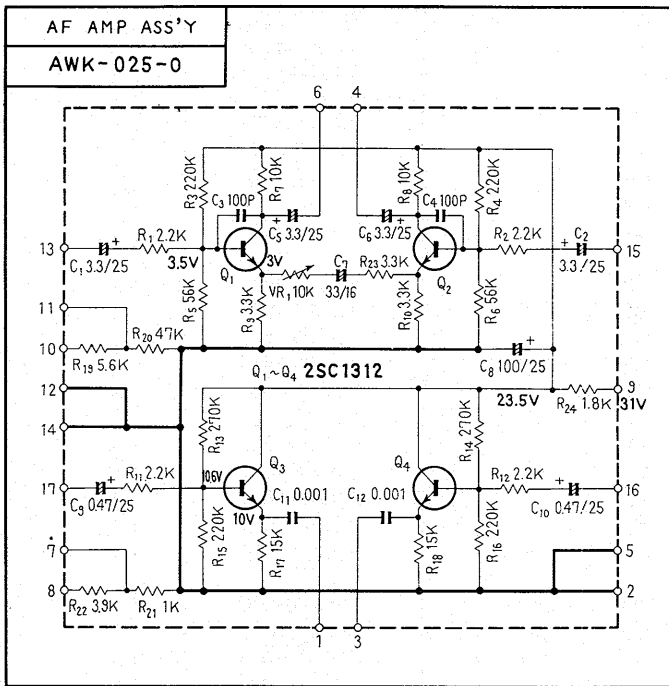

2SC1312

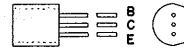

Foil side

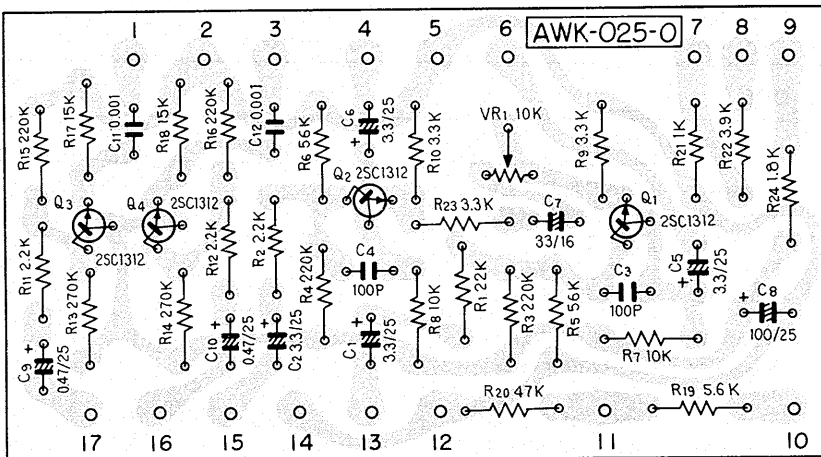

Parts List of AF Amplifier Assembly (AWK-025-0)

CAPACITORS

Symbol	Description	Part No.
C1	Electrolytic 3.3 25V	CSSA 3R3X 25
C2	Electrolytic 3.3 25V	CSSA 3R3X 25
C3	Ceramic 100p 50V	CCDSL 101K 50
C4	Ceramic 100p 50V	CCDSL 101K 50
C5	Electrolytic 3.3 25V	CSSA 3R3X 25
C6	Electrolytic 3.3 25V	CSSA 3R3X 25
C7	Electrolytic 33 16V	CEA 330M 16NP
C8	Electrolytic 100 25V	CEA 101P 25
C9	Electrolytic 0.47 25V	CSSA R47X 25
C10	Electrolytic 0.47 25V	CSSA R47X 25
C11	Mylar 0.001 50V	CQMA 102K 50
C12	Mylar 0.001 50V	CQMA 102K 50

RESISTORS AND POTENTIOMETER

Symbol	Description	Part No.
VR1	Semi-fixed 10k-B	C92-049-0
R1	Carbon film 2.2k	RD¼PM 222J
R2	Carbon film 2.2k	RD¼PM 222J
R3	Carbon film 220k	RD¼PM 224J
R4	Carbon film 220k	RD¼PM 224J
R5	Carbon film 56k	RD¼PM 563J
R6	Carbon film 56k	RD¼PM 563J
R7	Carbon film 10k	RD¼PM 103J
R8	Carbon film 10k	RD¼PM 103J
R9	Carbon film 3.3k	RD¼PM 332J
R10	Carbon film 3.3k	RD¼PM 332J
R11	Carbon film 2.2k	RD¼PM 222J
R12	Carbon film 2.2k	RD¼PM 222J
R13	Carbon film 270k	RD¼PM 274J
R14	Carbon film 270k	RD¼PM 274J
R15	Carbon film 220k	RD¼PM 224J
R16	Carbon film 220k	RD¼PM 224J
R17	Carbon film 15k	RD¼PM 153J
R18	Carbon film 15k	RD¼PM 153J
R19	Carbon film 5.6k	RD¼PM 562J
R20	Carbon film 47k	RD¼PM 473J
R21	Carbon film 1k	RD¼PM 102J
R22	Carbon film 3.9k	RD¼PM 392J
R23	Carbon film 3.3k	RD¼PM 332J
R24	Carbon film 1.8k	RD¼PM 182J

SEMICONDUCTORS

Symbol	Description	Part No.
Q1	Transistor 2SC1312-F or G	
Q2	Transistor 2SC1312-F or G	
Q3	Transistor 2SC1312-F or G	
Q4	Transistor 2SC1312-F or G	



# 12.10 POWER SUPPLY CIRCUIT ASSEMBLY (AWR-035-0)

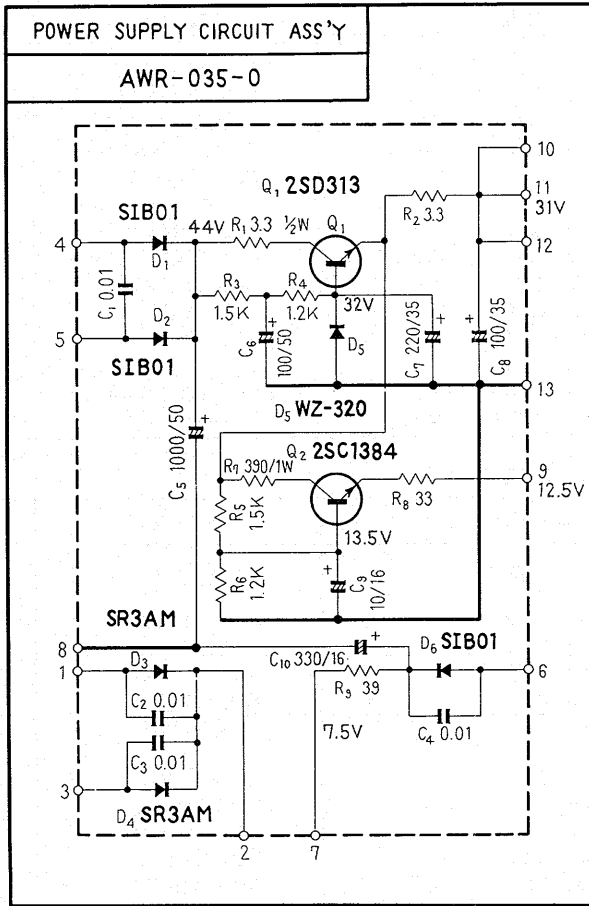

Foil side

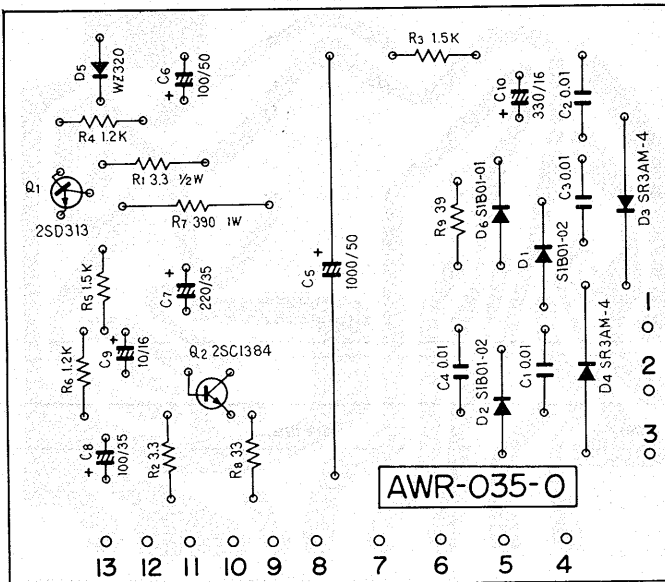

2SD313

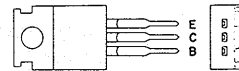

2SC1384

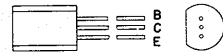

**Parts List of Power Supply Circuit Assembly (AWR-035-0)**

**CAPACITORS**

Symbol	Description	Part No.
C1	Ceramic 0.01 150V	ACG-002-0
C2	Ceramic 0.01 150V	ACG-002-0
C3	Ceramic 0.01 150V	ACG-002-0
C4	Ceramic 0.01 150V	ACG-002-0
C5	Electrolytic 1,000 50V	CEB 102P 50
C6	Electrolytic 100 50V	CEA 101P 50
C7	Electrolytic 220 35V	CEA 221P 35
C8	Electrolytic 100 35V	CEA 101P 35
C9	Electrolytic 10 16V	CEA 100P 16
C10	Electrolytic 330 16V	CEA 331P 16

**RESISTORS**

Symbol	Description	Part No.
R1	Carbon film 3.3 ½W	RD¼PM 3R3J
R2	Carbon film 3.3	RD¼PM 3R3J
R3	Carbon film 1.5k	RD¼PM 152J
R4	Carbon film 1.2k	RD¼PM 122J
R5	Carbon film 1.5k	RD¼PM 152J
R6	Carbon film 1.2k	RD¼PM 122J
R7	Metal oxide 390 1W	RS1P 391K
R8	Carbon film 33	RD¼PM 330J
R9	Carbon film 39	RD¼PM 390J

**SEMICONDUCTORS**

Symbol	Description	Part No.
Q1	Transistor 2SD313-E or D	
Q2	Transistor 2SC1384-R or Q	
D1	Diode SIB01-02	
D2	Diode SIB01-02	
D3	Diode SR3AM-4	
D4	Diode SR3AM-4	
D5	Zener diode WZ-320	
D6	Diode SIB01-01	

**OTHERS**

Symbol	Description	Part No.
	Heat sink	ANH-099-C
	Spacer	AEC-043-0

# 12.11 BALANCE VOLUME ASSEMBLY (AWX-028-0)

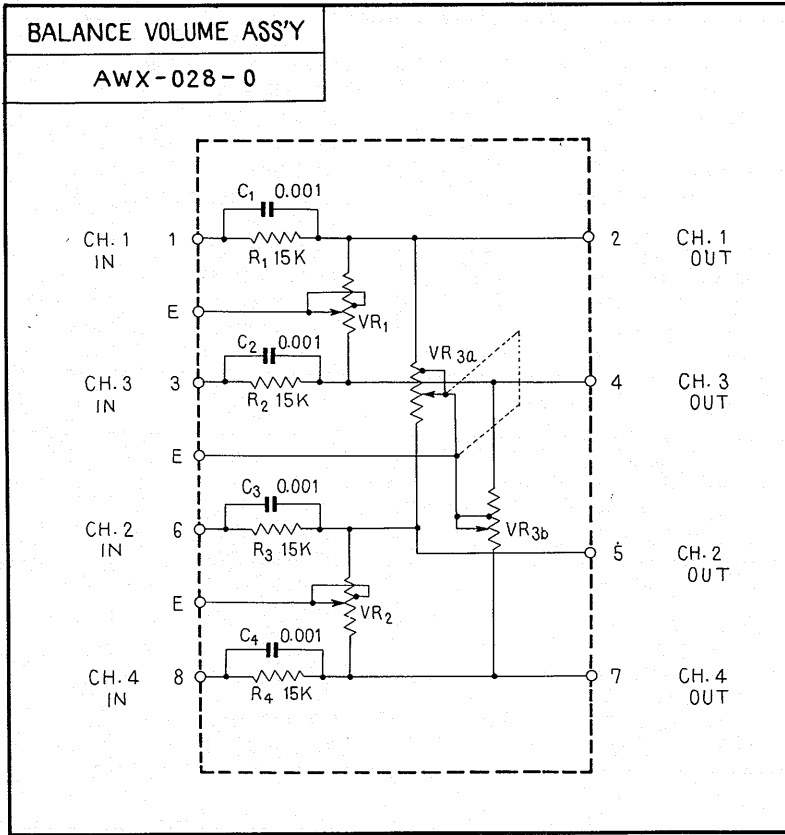

Foil side

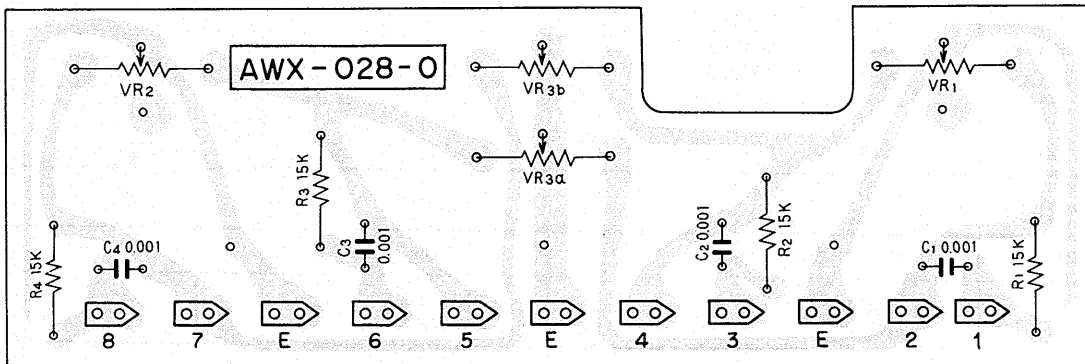

**Parts List of Balance Volume Assembly (AWX-028-0)**

**CAPACITORS**

Symbol	Description	Part No.
C1	Mylar 0.001 50V	CQMA 102K 50
C2	Mylar 0.001 50V	CQMA 102K 50
C3	Mylar 0.001 50V	CQMA 102K 50
C4	Mylar 0.001 50V	CQMA 102K 50

**RESISTORS AND POTENTIOMETERS**

Symbol	Description	Part No.
R1	Carbon film 15k	RD $\frac{1}{4}$ PS 153J
R2	Carbon film 15k	RD $\frac{1}{4}$ PS 153J
R3	Carbon film 15k	RD $\frac{1}{4}$ PS 153J
R4	Carbon film 15k	RD $\frac{1}{4}$ PS 153J
VR1	BALANCE (Front), 500k-B	ACV-008-0
VR2	BALANCE (Rear), 500k-B	ACV-008-0
VR3	BALANCE (DUAL), 500k-B	ACV-109-0

# 12.12 SWITCH CIRCUIT ASSEMBLY (AWS-023-0)

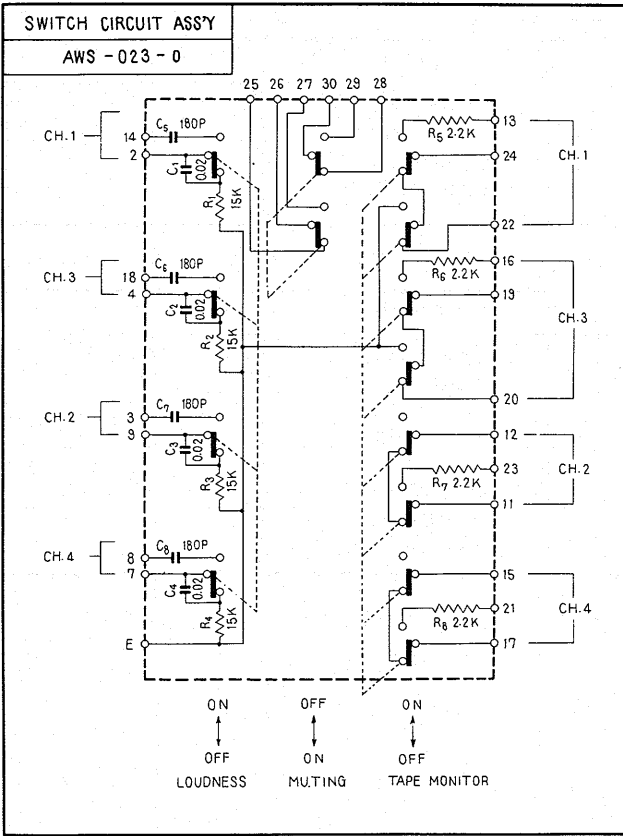

Foil side

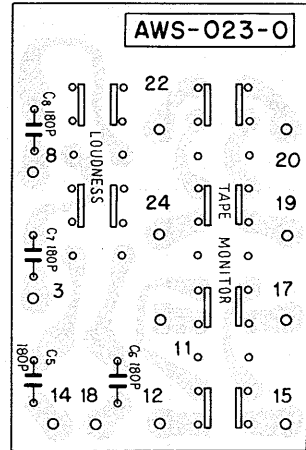

Foil side

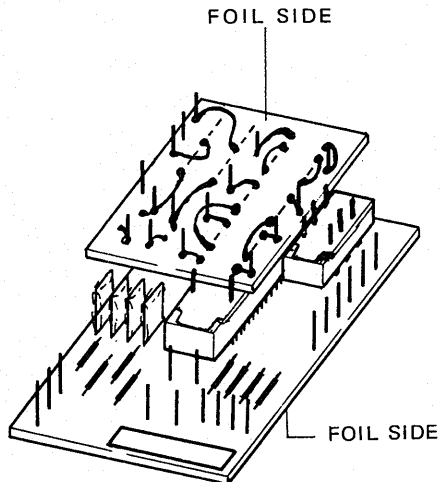
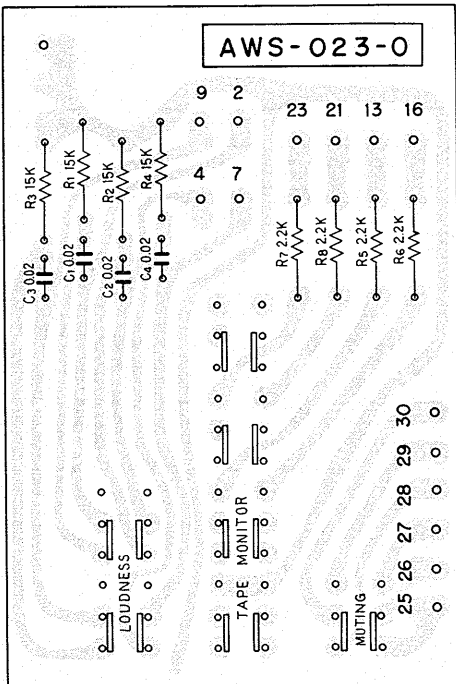

**Parts List of Switch Circuit Assembly (AWS-023-0)**

**CAPACITORS**

Symbol	Description			Part No.
C1	Mylar	0.02	50V	CQMA 203K 50
C2	Mylar	0.02	50V	CQMA 203K 50
C3	Mylar	0.02	50V	CQMA 203K 50
C4	Mylar	0.02	50V	CQMA 203K 50
C5	Ceramic	180p	50V	CCDSL 181K 50
C6	Ceramic	180p	50V	CCDSL 181K 50
C7	Ceramic	180p	50V	CCDSL 181K 50
C8	Ceramic	180p	50V	CCDSL 181K 50

**RESISTORS**

Symbol	Description			Part No.
R1	Carbon film	15k		RD½PS 153J
R2	Carbon film	15k		RD½PS 153J
R3	Carbon film	15k		RD½PS 153J
R4	Carbon film	15k		RD½PS 153J
R5	Carbon film	2.2k		RD½PS 222J
R6	Carbon film	2.2k		RD½PS 222J
R7	Carbon film	2.2k		RD½PS 222J
R8	Carbon film	2.2k		RD½PS 222J

**SWITCH**

Symbol	Description	Part No.
	Mini-switch (3-gang)	ASG-027-0

## 12.13 SPEAKER SWITCH CIRCUIT ASSEMBLY (AWS-024-0)

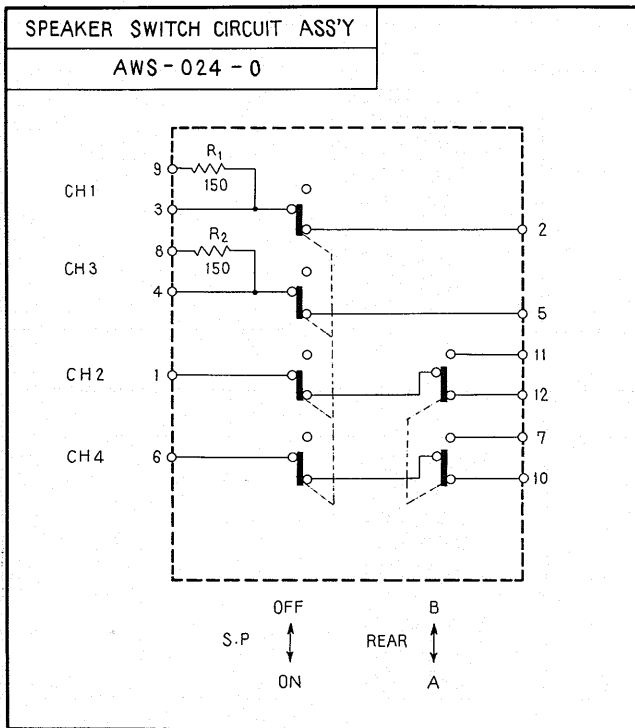

Foil side

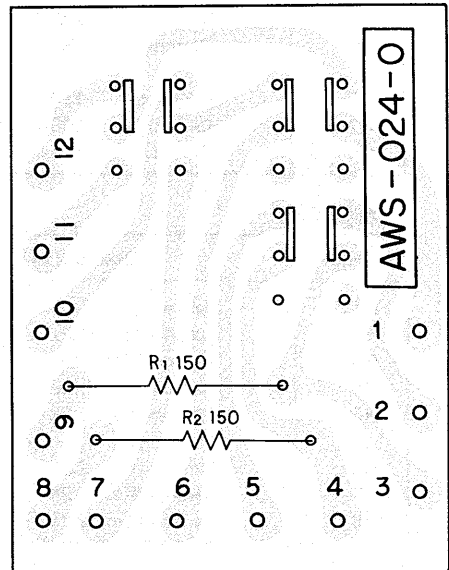

### RESISTORS

Symbol	Description	Part No.
R1	Metal oxide 150 2W	RS2P 151K
R2	Metal oxide 150 2W	RS2P 151K

### SWITCH

Symbol	Description	Part No.
	Mini-switch	ASG-026-0

### 13. PACKING METHOD AND PART NUMBERS

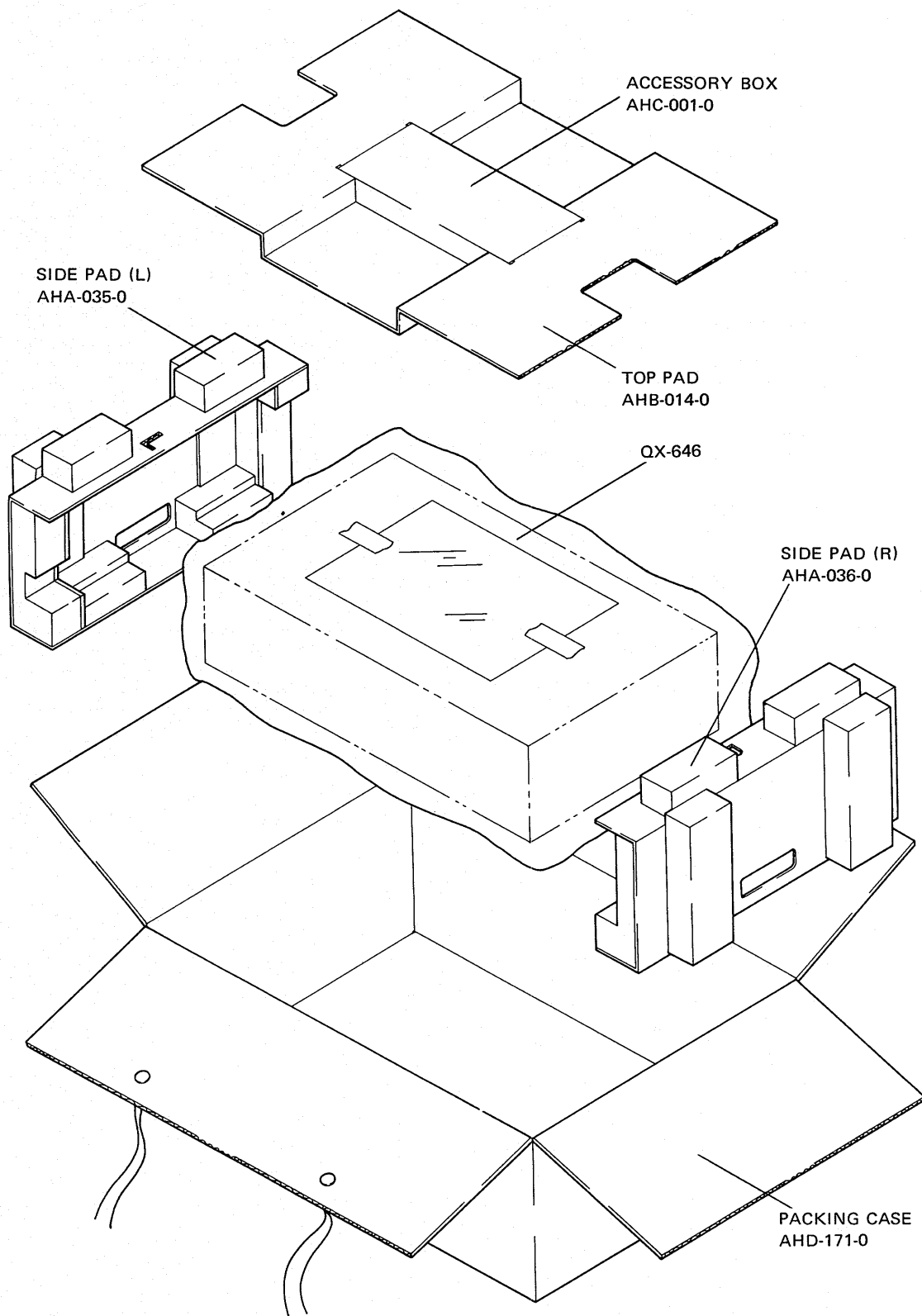



**PIONEER ELECTRONIC CORPORATION**

15-5, 4-Chome, Ohmori-nishi, Ohta-ku, Tokyo, Japan

**U.S. PIONEER ELECTRONICS CORPORATION**

178 Commerce Road, Carlstadt New Jersey 07072 U.S.A.

**PIONEER ELECTRONIC (EUROPE) N.V.**

Meir-center, Meir 21, 2000 Antwerp, Belgium

© APR. 1973

PRINTED IN JAPAN